

# LOKRING SINGLE RING

MECHANICAL TUBE JOINING SYSTEM FOR REFRIGERANT LINES

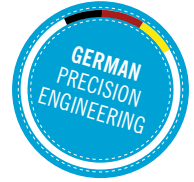

 solder-free  
tube connection



# VULKAN LOKRING

**VULKAN LOKRING.** LOKRING tube connections and tools are made by VULKAN Lokring in-house: Development, construction, manufacture as well as sales & service. For the customers, this means „all from a single source“ and directly from the manufacturer: customised planning and consultancy, supervision at the time of introduction, and support and service locally wherever required.



**RESEARCH AND DEVELOPMENT.** VULKAN Lokring is the inventor and developer of the patented LOKRING tube joint. For the last 36 years, experienced engineers have built new solutions for customers' applications in the development centre in Germany.



**PRODUCTION.** Approximately 500,000 LOKRINGS per day are produced on modern multi-spindle automatic machines in Germany, Brazil, India, USA and China. Therefore, for customers, LOKRING is the optimal partner when it comes to safety, flexibility and logistics.



**QUALITY.** The German standard of quality management is the benchmark for the international production of LOKRING. The certified quality management and the deployment of highly advanced industrial image processing systems facilitate 100% quality control.



**SERVICE.** Whether you are seeking planning and consultancy for optimising the refrigeration cycle system by using solder-free tube connections, support with the introduction of the LOKRING technology in production or after-sales service – everything is available locally with competent VULKAN Lokring technicians.



**PRODUCT AND MANAGEMENT CERTIFICATION.** TÜV and UL product certification. ISO 9001 certification of the quality management system. ISO 14001 certification of the environment management system. AEO certification. Leak-proof tests. Expert survey reports.



**CLIMATE PROTECTION.** Since our tube connections are hermetically sealed, we can ensure that no climate damaging refrigerants leak into the environment. Furthermore, LOKRING makes the use of environmental friendly but flammable refrigerants (HC) safer and allows the use of CO<sub>2</sub> (R744). Thus, by using LOKRING tube connections you make a contribution to the active protection of the environment.



**THE BEST CONNECTION – WORLDWIDE.** Operating with five international production locations, with 16 subsidiary companies and an additional 13 agencies worldwide, we ensure that VULKAN Lokring expertise is available on site throughout the world. This means that our customers have rapid access to our specialists and that the necessary solutions are quickly available exactly where they are needed.



**CUSTOMER REFERENCES.** A small selection from more than 7,000 satisfied customers:



FOR THE LAST 36 YEARS, **VULKAN LOKRING** HAS DEVELOPED, MANUFACTURED AND MARKETED **MECHANICAL TUBE JOINING SYSTEMS FOR REFRIGERANT LINES.**

**VULKAN Lokring** is a company that belongs to the VULKAN Group, which is a medium-sized family-owned enterprise for technical industrial applications with its head office in Germany. As a developer of the LOKRING technology, VULKAN Lokring is a market leader in the field of solder-free and non-detachable tube joints.

Developed originally for the most extreme conditions encountered in manned space travel, the LOKRING tube joining technique has undergone constant advanced development for applications in commercial refrigeration and air conditioning technology.

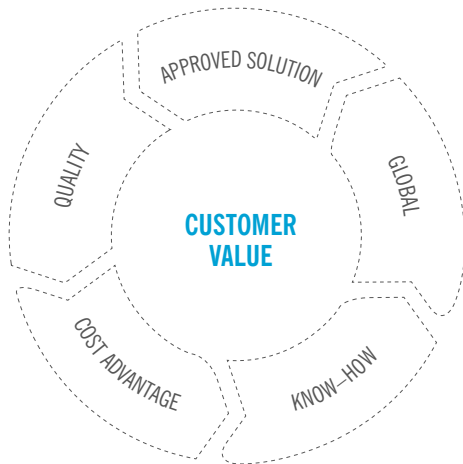

Therefore, VULKAN Lokring nowadays provides customised solutions for tube connections in the fields of the manufacturing, installation and servicing of refrigeration and air conditioning technology.

All from a single source – from separate development for customers to their own production range and right up to sales & service by local subsidiaries or authorised business partners.

**APPROVED SOLUTION**

**1,500,000,000** LOKRING® CONNECTIONS

have been successfully used in the industrial volume production of refrigerators, freezers and air conditioning systems.

**GLOBAL**

**470,000** LOKRINGS PER DAY

are produced in the 5 international manufacturing facilities of VULKAN Lokring on modern multi-spindle automatic lathe machines and shipped to 83 destination countries.

**COST ADVANTAGE**

**7,000** CUSTOMERS

optimise their international competitive edge by using LOKRING tube connections as cost and quality benefit compared to brazed ones.

**KNOW-HOW**

**650** UNIQUE TYPES OF LOKRING

are used at present by customers in order to optimally join tubes made of different materials and combinations of diameters.

**QUALITY**

**100%** QUALITY INSPECTION

of LOKRING based on automated industrial image processing as part of the certified VULKAN Lokring quality management system.

---

# CONTENTS

---



## VULKAN LOKRING COMPACT

---

VULKAN LOKRING IN BRIEF  
VULKAN LOKRING WORLDWIDE  
VULKAN LOKRING REFERENCES

→ 02

## LOKRING SINGLE RING

---

02 THE BEST CONNECTION  
04 FUNCTIONAL PRINCIPAL  
05 THE BENEFITS  
06 TREND OF RAW MATERIALS

→ 08

## REFRIGERATOR APPLICATIONS

---

10 THE CYCLE SYSTEM OF A REFRIGERATOR  
12 EVAPORATOR SECTION  
16 CONDENSER SECTION  
20 DRYER SECTION  
24 COMPRESSOR SECTION

→ 28

## AREAS OF NEW APPLICATIONS

---

→ 34

## TOOLS & FUNCTION

---

36 LOKRING SINGLE RING  
38 LOKPREP  
40 PINCH-OFF AND ASSEMBLY TOOL  
42 HYDRAULIC FLARING TOOL  
44 HYDRAULIC ASSEMBLY TOOL  
46 HYDRAULIC AGGREGATE R2.5

→ 48

## LOKRING SERVICE SOLUTIONS

---

→ 54

## VULKAN LOKRING COMPANIES

---

→ 56

## ONLINE-SERVICE

---

# THE BEST CONNECTION

**THE LOKRING SINGLE RING TECHNOLOGY** is a method for connecting metallic refrigerant lines without brazing so that they are permanent and hermetically sealed. For this purpose, VULKAN Lokring constructs customised LOKRING tube connections for any application based on the tube materials, dimensions and tolerances and the associated assembly tools. The primary area of application is the manufacture of the refrigerant circuit in the series production of refrigerators and freezers. There are other applications for the manufacture of evaporators for automotive air-conditioning systems, for heat exchangers in refrigeration and air-conditioning technology (e.g. manufacture of heat pumps) or with the serial installation of refrigeration and air-conditioning technology (e.g. air-conditioning for buses). Whether it is a matter of optimising costs, improving quality or solving a problem – LOKRING SINGLE RING is the answer!

**REFRIGERATORS AND FREEZERS.** This is where the use of LOKRING has been proven a billion times over for the last 36 years. Nonetheless, it is in this segment that many LOKRING SINGLE RINGS are being constructed at present for new applications so that an increasing number of brazed connections are being replaced by LOKRING.

You can find more information on pages 08 – 27.



**AUTOMOTIVE AIR-CONDITIONING.** LOKRING has been a supplier of tube connections for the initial fitting of air-conditioning components to leading suppliers in the automotive industry for many years. The LOKRING SINGLE RING is being used for the series manufacture of evaporators and heat exchangers made of aluminium.

You can find more information on pages 30 – 31.





## HOW CAN WE CONNECT YOU?

Would you like to cut costs, improve the quality or solve a problem while manufacturing a refrigerant circuit? Would you like to dispense with brazing at a specific connection or dispense with it completely?



Please contact VULKAN Lokring and we will find a solution for your application. You will find contact information on pages 54 – 55.



**HEAT EXCHANGERS / HEAT PUMPS.** Situations may arise while installing heat exchangers into a refrigerant circuit, resulting from construction-related or material-related constraints that make brazing impossible or uneconomical. An example of the solution for such a Cu-Ti tube connection in a Heat pump using LOKRING SINGLE RING is illustrated on page 33.



You can find more information on page 33.



**BUS AIR-CONDITIONING.** Aluminium lines are increasingly being used in the installation of bus air-conditioning systems due to cost and weight considerations. This is facilitated by the use of LOKRING SINGLE RING as an efficient and reliable alternative to brazing.



You can find more information on page 32.





# FUNCTIONAL PRINCIPAL

**THANKS TO THE CONICAL INNER CONTOUR** of the LOKRING, the diameter of the outer tube is reduced during assembly to such an extent that the inner tube and the outer tube create a hermetically sealed metal-to-metal connection. The lifetime gas-tightness of the fitted connection is ensured by the state of permanent elastic pre-tension, which is produced by the radial forces of the LOKRING acting in the opposite direction to the connection between the outer tube and the inner tube.

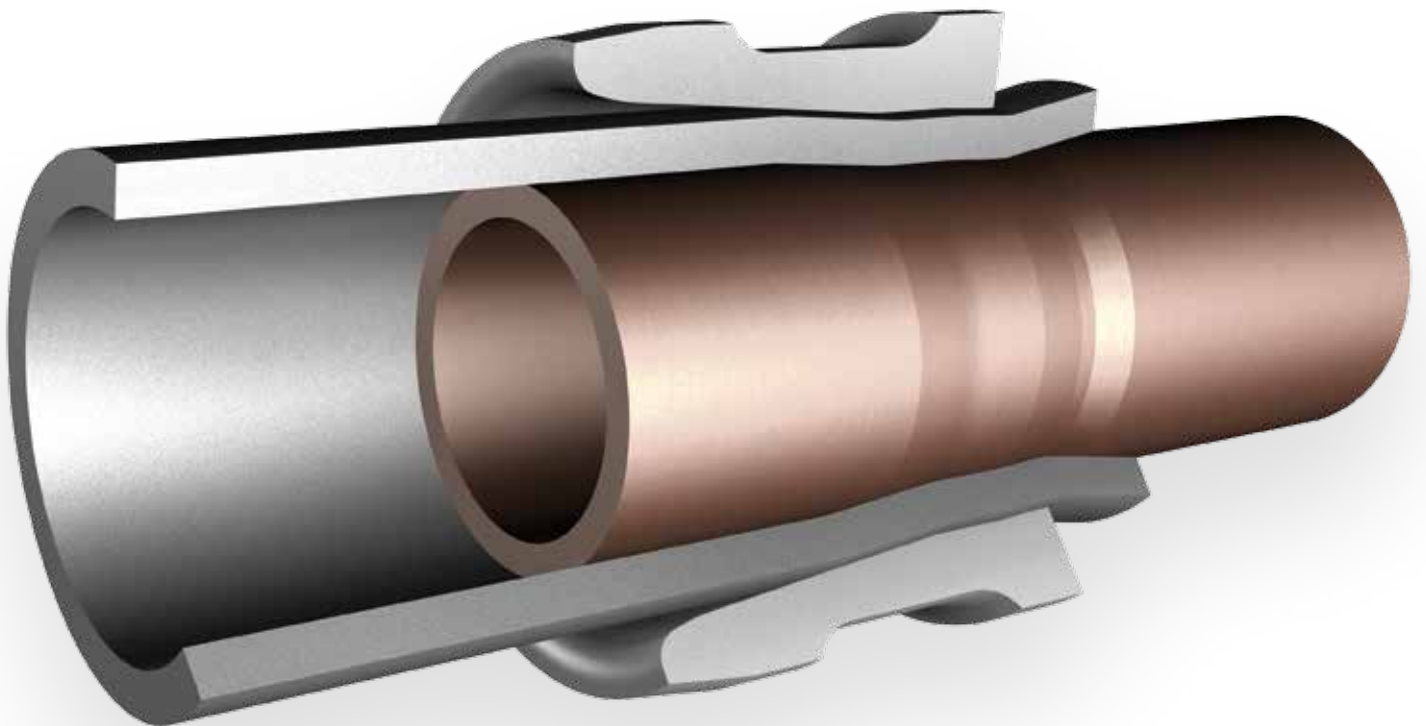



# THE BENEFITS

## LOKRING IS BETTER



LOKRING is the preferred alternative to brazing as it is more cost effective, delivers better quality with less failure and leak rates, as well as being faster. Furthermore, it provides an excellent opportunity to switch tubes and components of the cycle system to cost saving materials (e.g. aluminium).

## LOKRING IS COST EFFECTIVE



LOKRING directly saves the costs for silver solder and highly trained operators. Meanwhile, LOKRING indirectly reduces potential brazing cost implications that might occur through leaks, corrosion, harmful fumes, damage, burns or tube preparations. LOKRING may even reduce the number of joints needed and the consumption of expensive Cu components.

## LOKRING IS BETTER QUALITY



A correctly made LOKRING joint ensures both a zero failure rate and zero leak rate in both plant and field. In addition, the LOKRING joint is very clean both inside and outside and there is no possibility of damage and burns occurring from brazing inside a cabinet. Finally, it ensures that there is no corrosion on grinded St tubes and no hazardous brazing fumes.

## LOKRING IS FASTER



A LOKRING joint needs just 10 seconds. As the net time of brazing may not be higher, the gross time of brazing – which includes such additional operations as grinding, coating and scale removal etc. – makes LOKRING the clear winner. And the more LOKRINGS that are applied, the more significant becomes the time advantage.

## FORWARD – LOOKING SOLUTIONS



As it is the preferred material for brazing, Cu material is extensively used in refrigerant cycle systems. However, Cu is heavy and expensive. For example, in the highly innovative automotive industry, all refrigerant lines are Al material. By “joining” LOKRING you can finally consider the new possibilities!

## MATERIAL COMBINATIONS



As LOKRING can join any tube materials with the same level of quality, you can switch the components and tubes of the cycle system to the most feasible and most cost effective material – regardless of brazing standards.

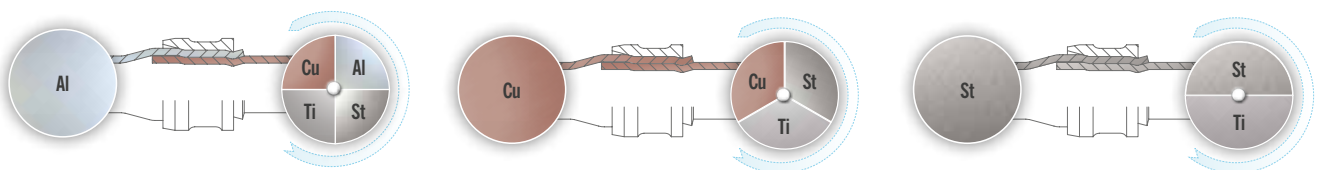

# TREND OF RAW MATERIALS

**COPPER, ALUMINIUM AND STEEL RAW MATERIAL.** The applied raw materials for components and tubes in a refrigerant cycle system are an essential input factor behind the cost of production. The following price chart shows the price of raw materials from 2005 to December of 2014, as well as anticipated price trends up to 2018, on the assumption that there will be consistency in the historical rate of price increases.

## COPPER, ALUMINIUM, STEEL: CHART OF RAW MATERIAL PRICE | kg. in Euros

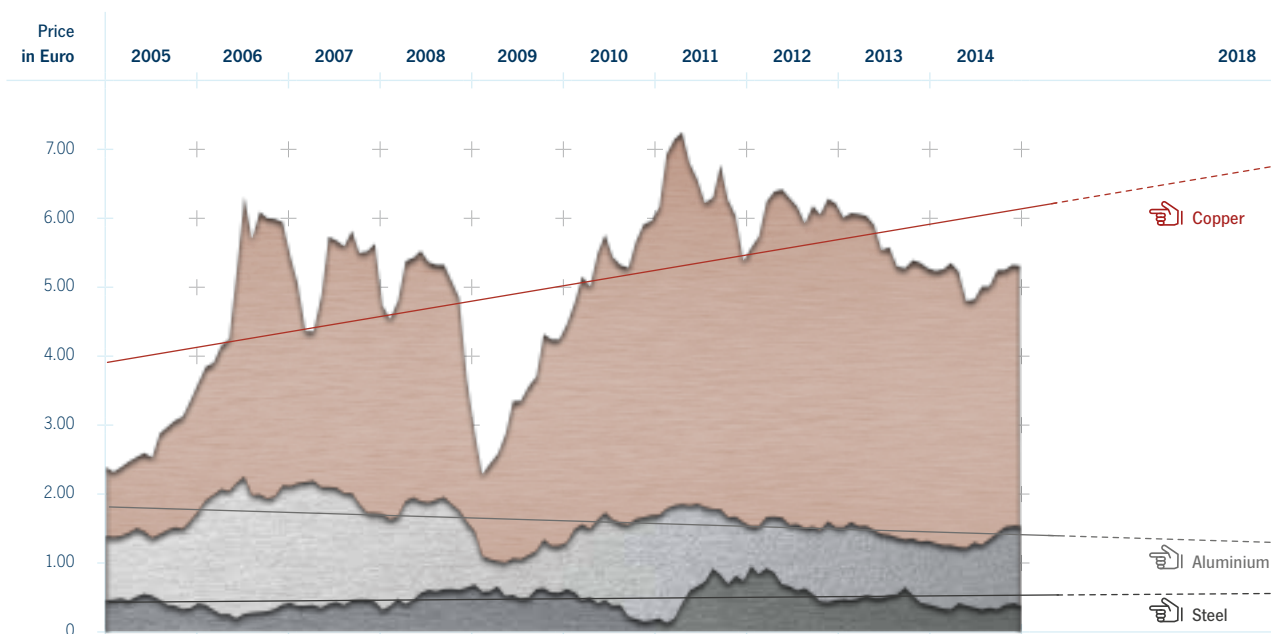

FIGURE 1: chart of copper, aluminium and steel raw material/kg in Euro (12.2014).

**COPPER VERSUS ALUMINIUM AND STEEL.** As copper material is used for many components and refrigerant lines in the refrigeration industry, it plays a significant role in the cost of production. Since 2009, the price of copper material has increased by more than 250%, with an average yearly increase in the long term anticipated to be 7%. Conversely, the price of aluminium has actually decreased over the long term since 2005, while the price of steel has remained constant during this period.

For obvious reasons, the automotive industry – which is particularly known for high cost pressure – is using only aluminium material, which when taking into consideration the light weight (1/3 the weight of steel), is the most economical material for components and refrigerant lines. However, with aluminium comes the problem of brazing. With LOKRING, this is not a problem as it can easily join tubes of any material. Therefore, LOKRING can help you to reduce your production costs!

**SILVER SOLDERING.** The cost of silver soldering is dependent on the following factors: silver price, gram (g) of silver solder per joint and the percentage (%) of silver in the soldering flux. The following chart shows the exemplary costs of one soldered joint of minimum quality (0.6g/ 20%) and one of maximum quality (1.0 g/ 30%) and the corresponding anticipated cost trends to 2018, once again assuming the silver price increases consistency in line with historical trends.

### SILVER SOLDERING: CHART OF PRICE PER JOINT | in Euros

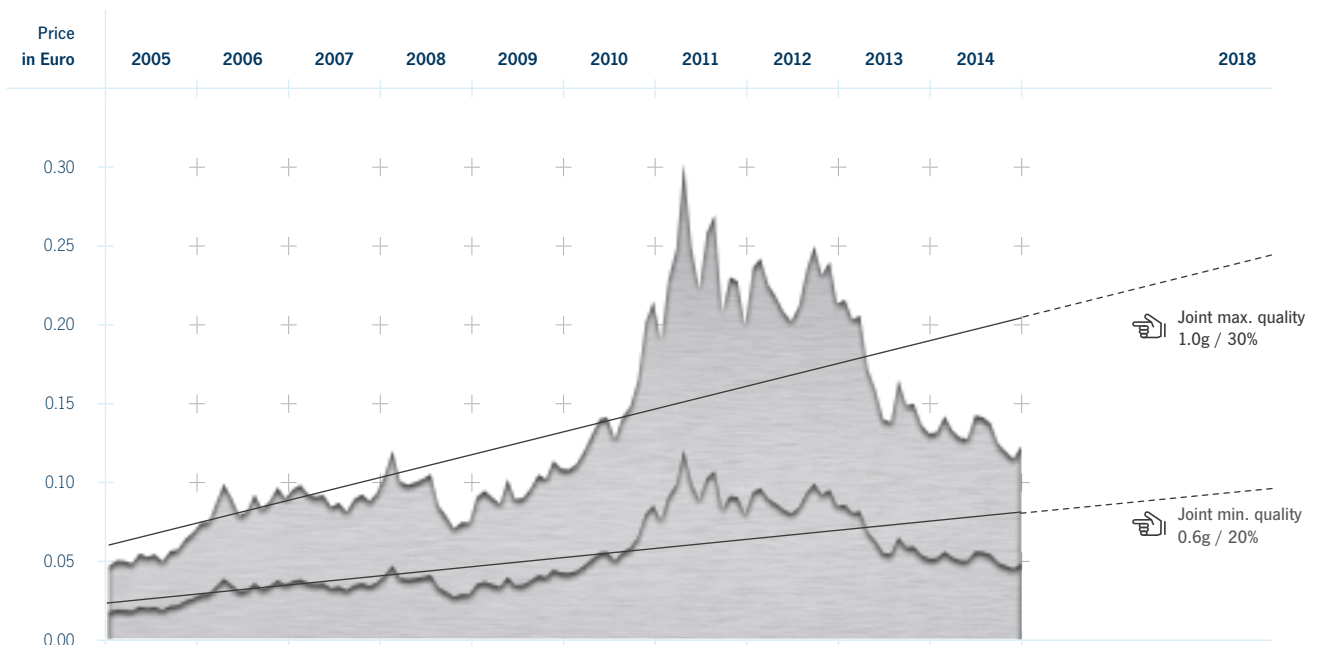

FIGURE 2: chart of costs for soldered joints with 0.6g / 20% and 1.0g / 30% in Euro (December 2014).

**LOKRING VERSUS SILVER SOLDERING:** Silver soldering has become increasingly expensive and the exposure to the anticipated future price increases of silver represents a significant risk in terms of any cost planning. Meanwhile, the price for LOKRING SINGLE RING is not only cost effective but should also prove to be constant in the long term!







# REFRIGERATOR APPLICATIONS

# REFRIGERATORS AND FREEZERS

**THE CYCLE SYSTEM OF A REFRIGERATOR** can be segmented into four sections: evaporator, condenser, dryer and compressor. The segmented cycle system below is a no frost model comprising two condensers and it is displaying the maximum quantity of 12 LOKRING SINGLE RING applications (10 tube joinings and 2 pinch-off pinchings). As the cycle system is the heart of every refrigerator, these 12 points are essential as regards operability, reliability and thus the overall success of a refrigerator. In the following chapters of this catalogue we will discuss and outline the advantages of choosing LOKRING SINGLE RING solutions rather than opting for brazing each section and individual application.

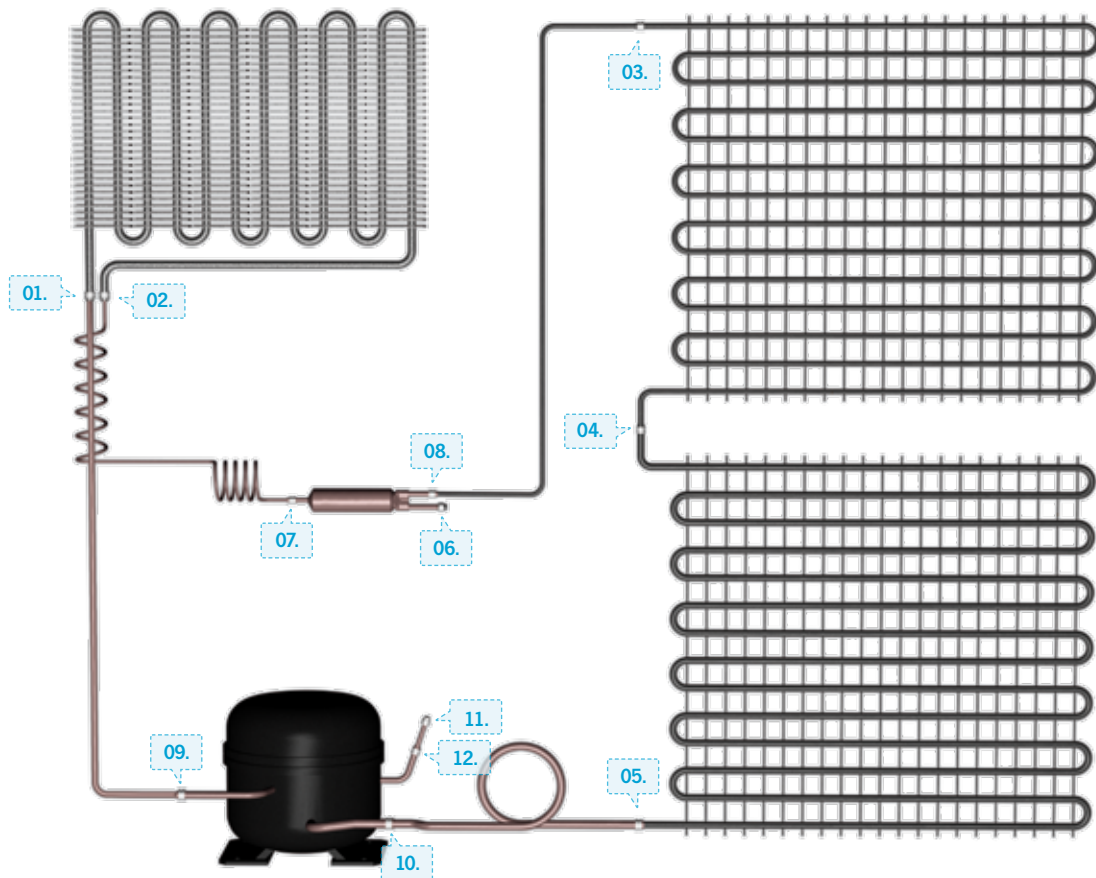

## EVAPORATOR SECTION

- 01. Evaporator to Suction Line
- 02. Capillary Tube to Evaporator

## CONDENSER SECTION

- 03. Backplate Condenser to Hotline
- 04. Sideplate Condenser to Backplate Condenser
- 05. Water Evaporation Coil to Sideplate Condenser

## DRYER SECTION

- 06. Dryer Pinch-off Pinching
- 07. Dryer to Capillary Tube
- 08. Hotline to Dryer

## COMPRESSOR SECTION

- 09. Suction Line to Compressor
- 10. Compressor to Water Evaporation Coil
- 11. Charging Pinch-off Pinching
- 12. Compressor to Charging Pinch of Pinching



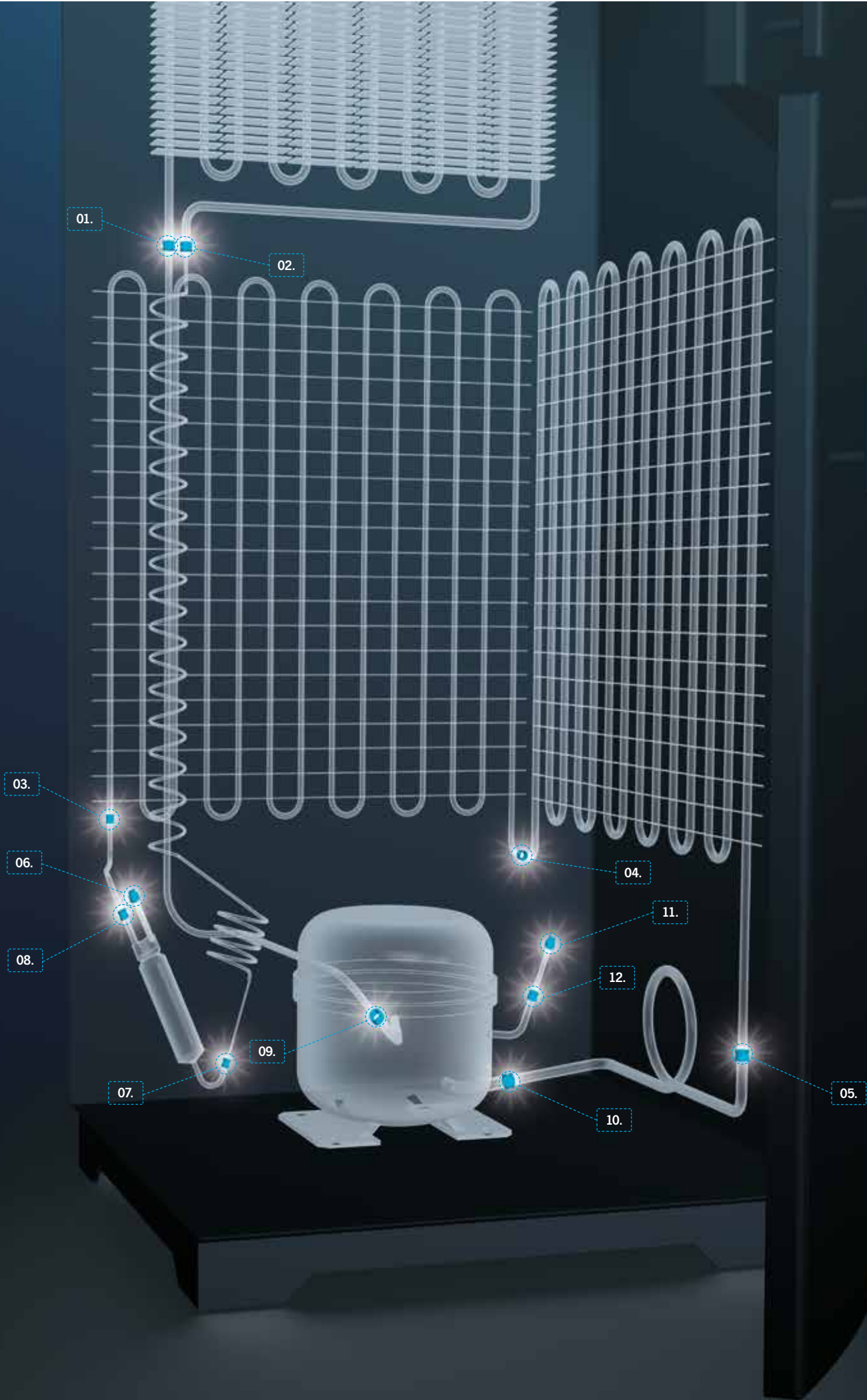



# EVAPORATOR SECTION

**EVAPORATOR SECTION** Generally, the evaporator is made of aluminium and as it is not possible to braze Al to Cu in the plant, the evaporator supplier has to supply the evaporator with Al to Cu connectors at suction, as well as on the capillary side. The manufacturer is then brazing the Cu suction tube and Cu capillary tube to the Al to Cu connectors inside the cabinet in the plant. Therefore, the conventional way results in a total of 4 joints: 2 Al to Cu connectors made by the evaporator supplier and 2 Cu to Cu joints brazed by the manufacturer. However, by choosing LOKRING you can reduce the total number of joints to 2 Al to Cu joints or even 2 Al to Al joints and also experience plenty of associated advantages!

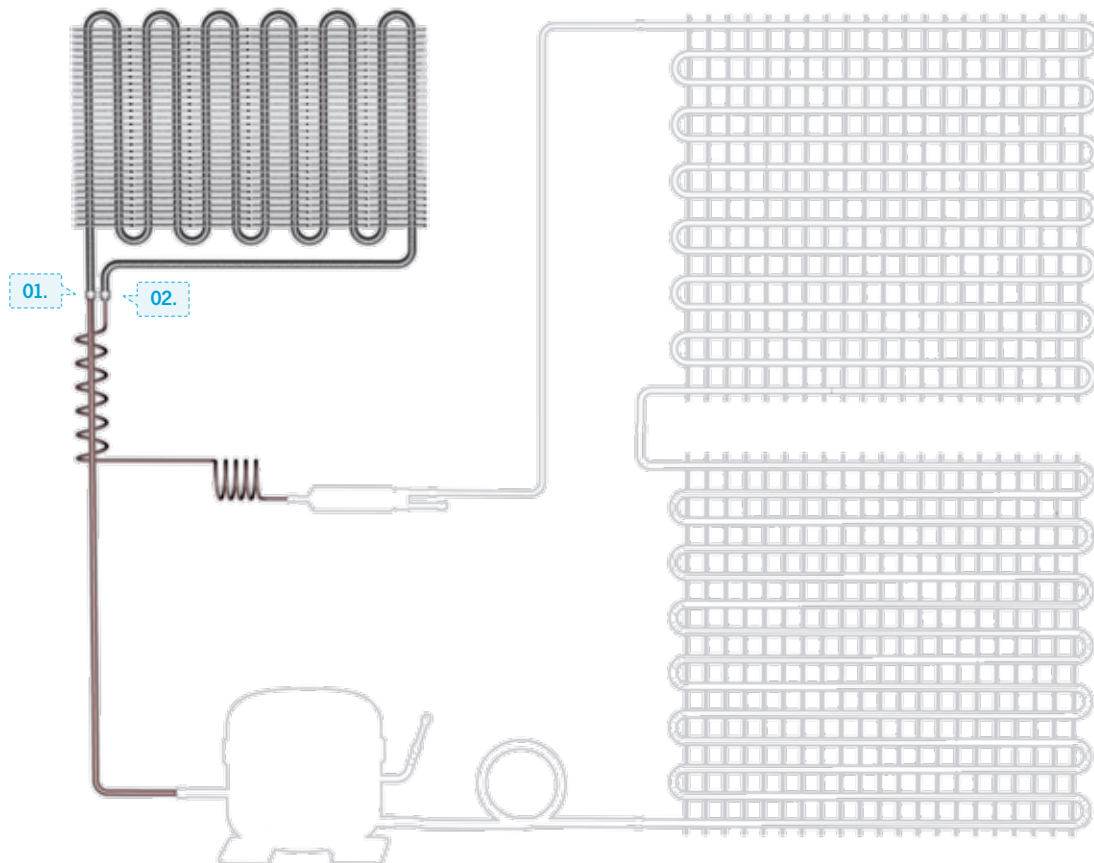

01. Evaporator to Suction Line



02. Capillary Tube to Evaporator



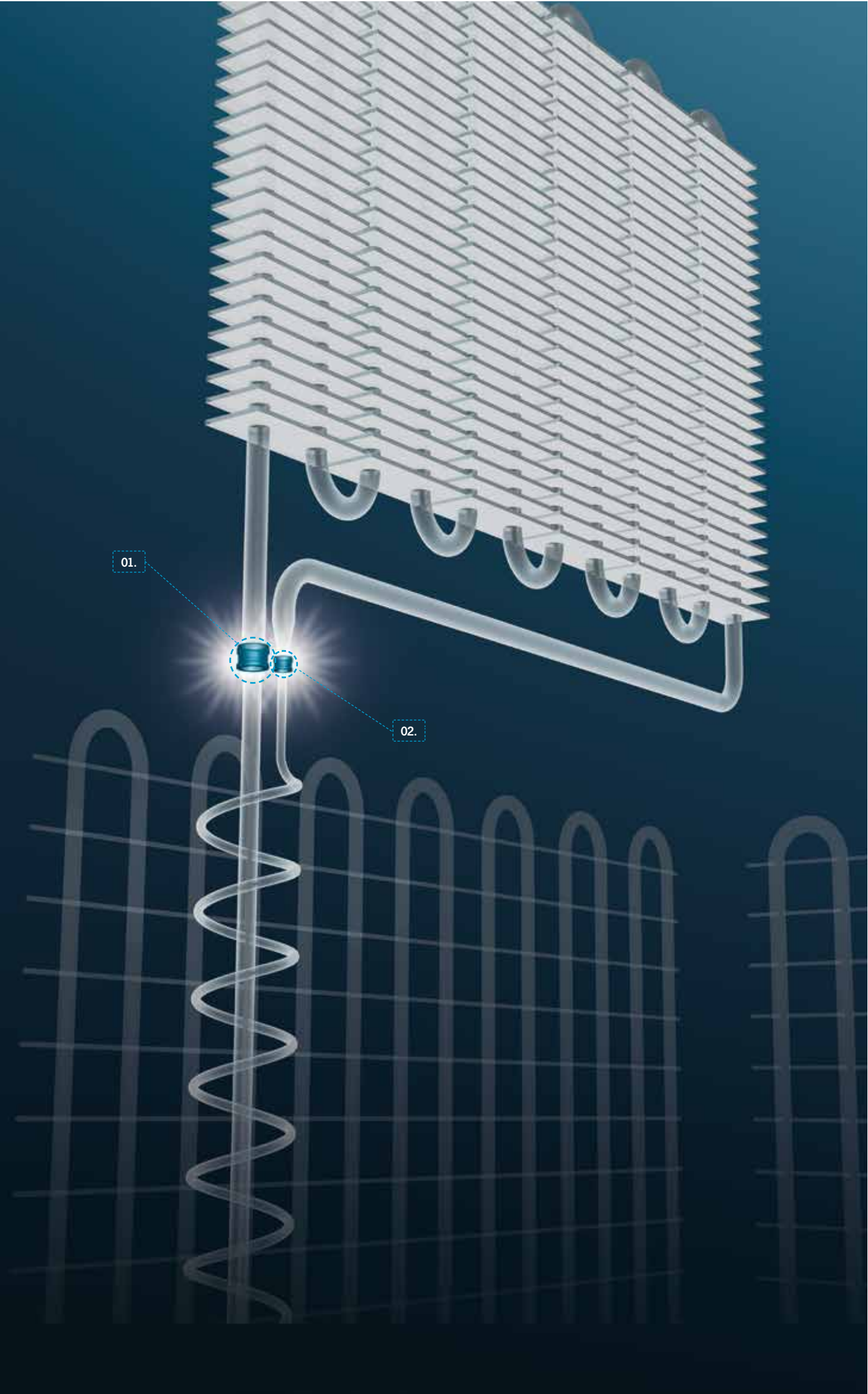

01.

02.

# EVAPORATOR SECTION

**LOKRING SINGLE RING.** When using LOKRING, no Al to Cu connectors by the evaporator supplier are required. The manufacturer can directly join the Al evaporator to the Cu suction line and to the Cu capillary tube with just 2 joints. There is no chance of damage, burning or health hazards due to brazing inside the cabinet and no skilled operator is required.

## 01. EVAPORATOR TO SUCTION LINE. Straightforward Al to Cu joint.

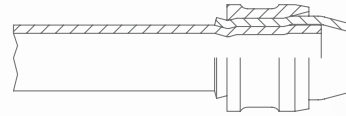

### SOLDER – FREE TUBE CONNECTION

- ⊕ No soldering or welding.
- ⊕ No fire protection requirements or safety requirements.
- ⊕ No use of nitrogen to prevent oxygenation.
- ⊕ Down swaging of Al tube on capillary side of the evaporator is required.

### MATERIAL COMBINATION

- ⊕ Easy connection of Al evaporator to the Cu suction line and to the Cu capillary tube.

### COSTS

- ⊕ No need for skilled operator.
- ⊕ As the manufacturer is reducing the costs of 2 joints (no Al to Cu connectors by the evaporator supplier) the supplier of the evaporator can reduce the price for the evaporator.

### QUALITY

- ⊕ 50% less potential of leaks, as the number of joints is reduced from 4 to 2.
- ⊕ No chance of damage and burns from brazing inside the cabinet.
- ⊕ Very clean both outside and inside.
- ⊕ No risk of choking of capillary tube due to brazing.

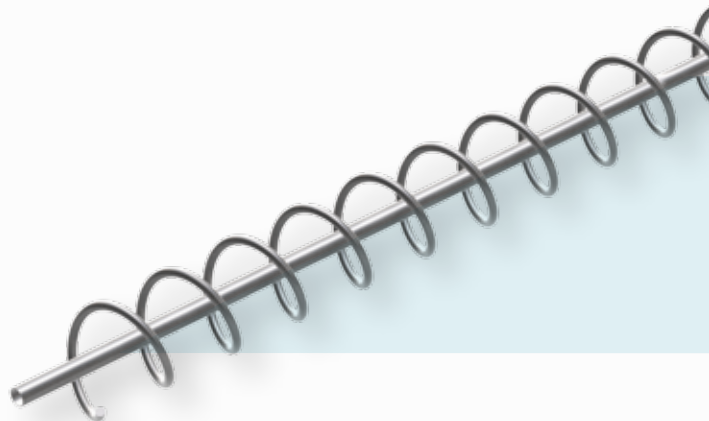
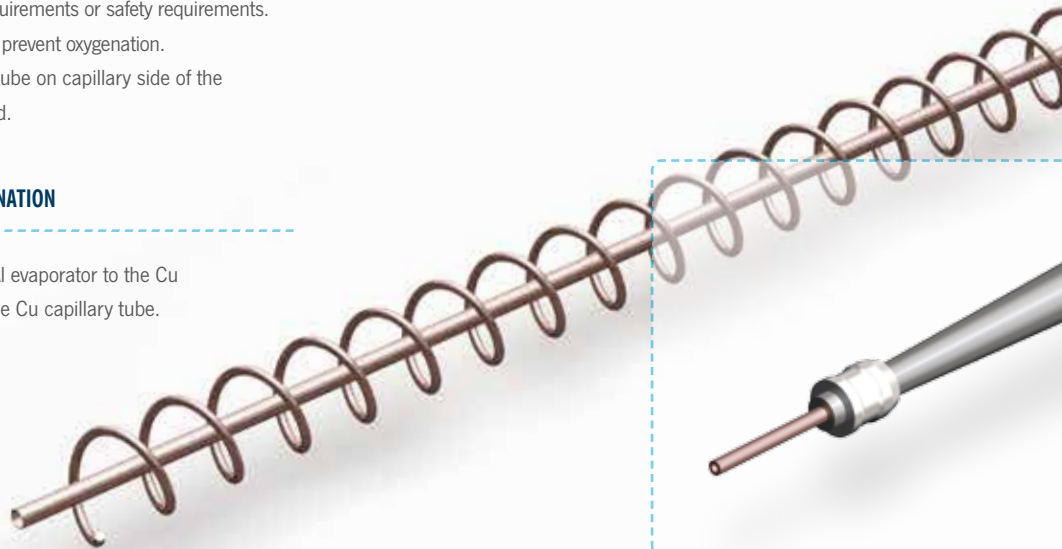

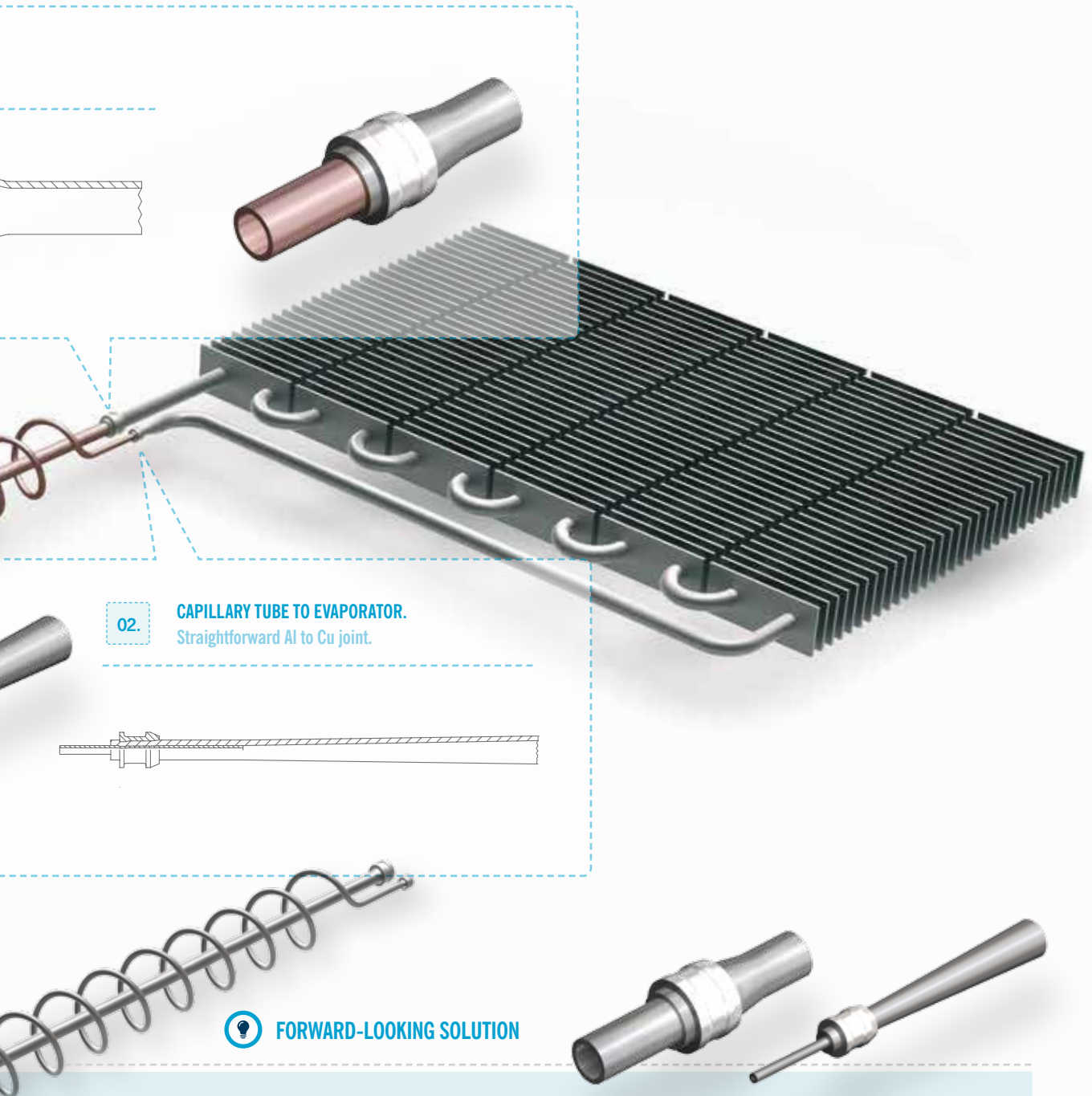

02.

### CAPILLARY TUBE TO EVAPORATOR.

Straightforward Al to Cu joint.

### FORWARD-LOOKING SOLUTION

- As the material costs for copper tubes are constantly increasing, it becomes a critical cost factor (see page 06 –07). The fact that LOKRING can easily connect Al to Al tubes means that the suction tube and capillary tube can be replaced by cheaper Al tubes. Save costs and improve the quality at the same time.
- Change the suction line and capillary tube from expensive Cu to cheaper Al material.
- Join Al evaporator with Al Suction tube and Al capillary tube in a straightforward manner.



# CONDENSER SECTION

**CONDENSER SECTION.** This model of refrigerator has two condensers – a back plate condenser and an additional side plate condenser. Therefore, in total, the condenser section has 3 critical joints. One St to St joint from the back plate condenser to the hotline and a second St to St joint from the side plate condenser to the back plate condenser. The third joint from the water evaporation coil to the back plate condenser is a Cu to St joint. All 3 joints are brazed with expensive silver solder, which necessitates the preparation of the St tube and protection of the connection point against corrosion, and they all have a maximum leak rate.

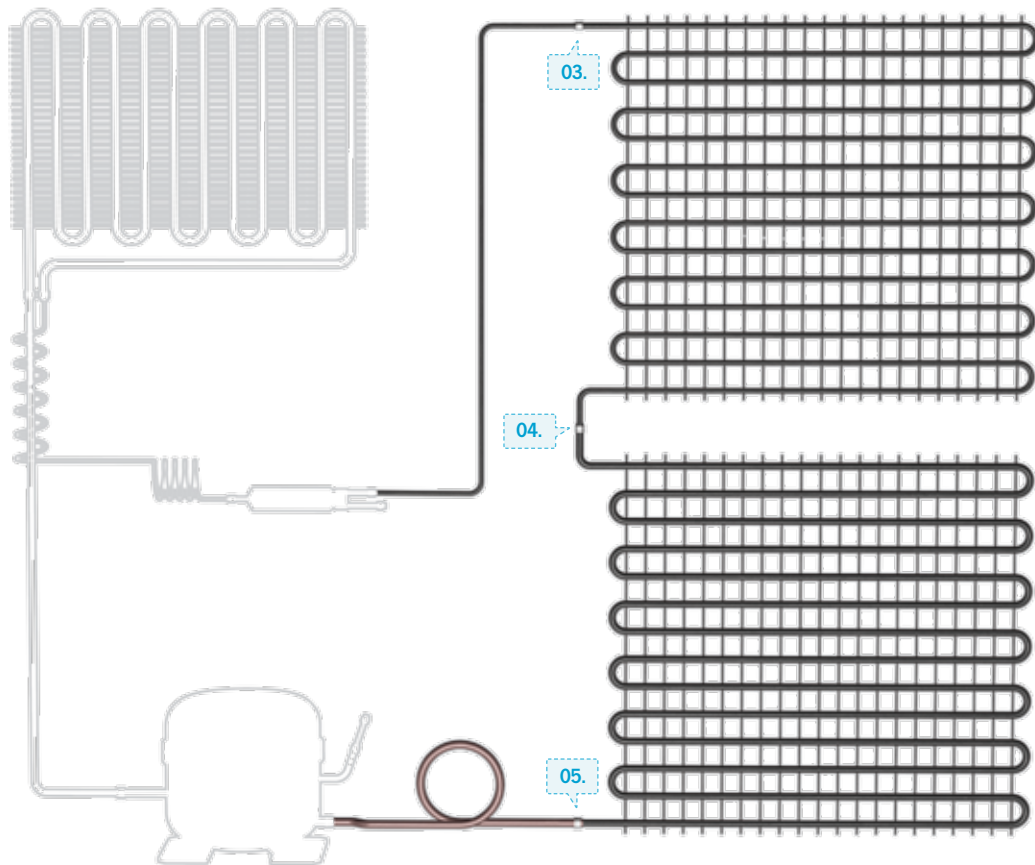

03.

Backplate Condenser to Hotline

04.

Sideplate Condenser to Backplate Condenser

05.

Water Evaporation Coil to Sideplate Condenser



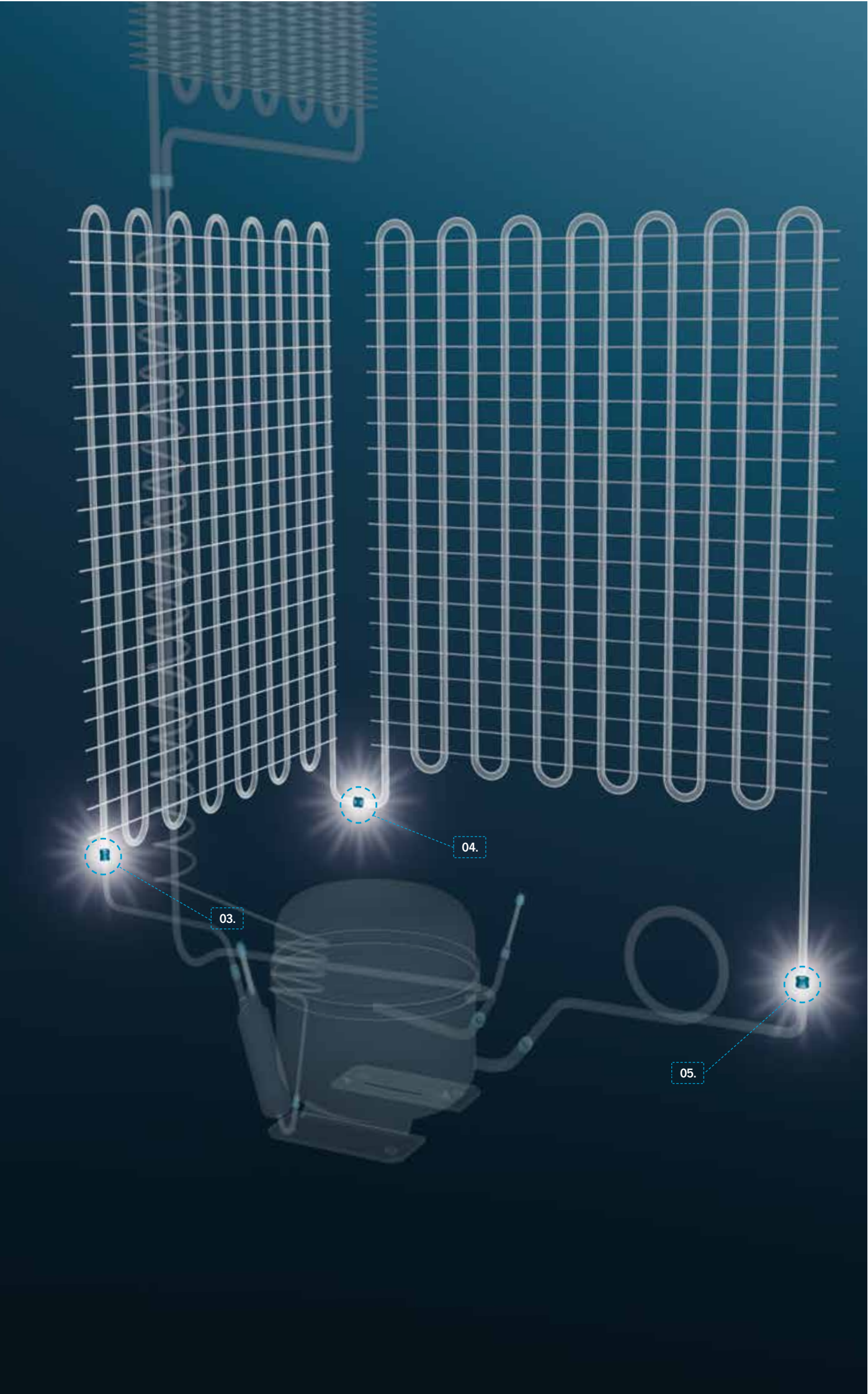

# CONDENSER SECTION

THE LOKRING SOLUTIONS



03.

**BACKPLATE CONDENSER TO HOTLINE.**  
St to St joint.

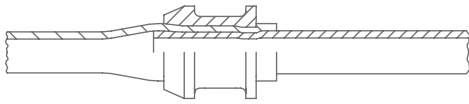

04.

**SIDEPLATE CONDENSER TO BACKPLATE CONDENSER.** St to St joint

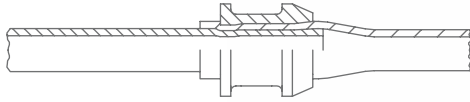

05.

**WATER EVAPORATION COIL TO SIDEPLATE CONDENSER.** Cu to St joint.

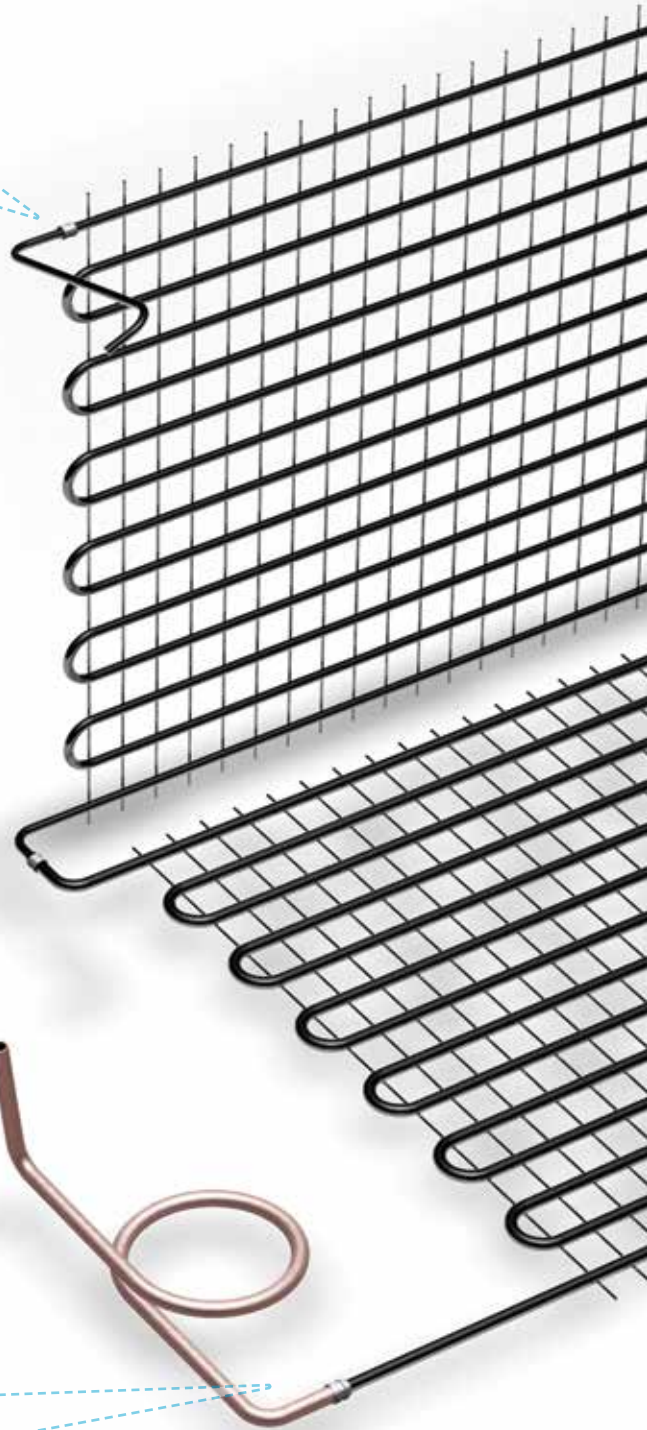
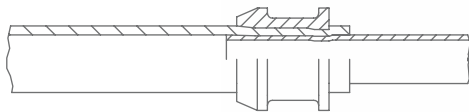





## PROBLEMS OF BRAZING

- ⌚ For brazing these joints, silver solder of 30% is typically used – this is very expensive!
- ⌚ Due to critical joint, generally speaking, the most skilled operator is used to braze these joints.
- ⌚ Maximum rate of leakages both in the plant and in the field.
- ⌚ The potential to overlook faults at the solder seam of the St tubes is quite high.
- ⌚ For brazing, an additional operation of grinding is required to remove the zinc plating of the St tube.
- ⌚ If tubes with a different kind of St material are preheated for brazing, the “weaker” tube gets brittle, resulting in damage.
- ⌚ To avoid corrosion after removing the zinc coating, the connection points have to be painted or protected by a shrinking hose.
- ⌚ The joint looks very unclean after brazing and scale removal is required.
- ⌚ Protective equipment against harmful brazing fumes is necessary.



## SOLDER – FREE TUBE CONNECTION

- ⌚ As LOKRING is a cold connection you do not face any problems induced by brazing a St to St or Cu to St joint.
- ⌚ The switch from brazing to LOKRING is easy and can be implemented immediately as no major changes are required.



## MATERIAL COMBINATION

- ⌚ Joining both St to St and St to Cu with LOKRING is a reliable, fast and easy operation that takes just 10 seconds.



## COSTS

- ⌚ No need for expensive silver solder.
- ⌚ No skilled operators required.
- ⌚ No extra costs through leaks in plant or after sales service costs.
- ⌚ No protective equipment required against harmful brazing fumes.



## QUALITY

- ⌚ No leakages either in field or in production.
- ⌚ No points of attack for corrosion on the St tube (no removing of zinc coating).
- ⌚ Very clean both inside and outside.
- ⌚ No hazardous brazing fumes.



## TIME

- ⌚ No additional operation of grinding to remove the zinc coating of the St tubes.
- ⌚ No additional operation of applying paint or using shrinking hose for protection against corrosion.
- ⌚ No scale removal of the soiled joint after brazing is required.



## FORWARD-LOOKING SOLUTION

- ⌚ Using LOKRING on the condenser(s) can reduce material costs as the wall thickness of tubes can be reduced to 0.5 mm.
- ⌚ As the weight of Al is 1/3rd of St and the price is nearly double, costs can be reduced by using LOKRING and switching the condenser(s) from St to Al.

# DRYER SECTION

**DRYER SECTION.** The dryer has 2 critical joints. One is the dryer to the capillary tube joint (Cu to Cu) which, when brazing, is most critical for choking or leakages, and this is worsened by the high rate of leakages from the field which result in extra costs in terms of after sales servicing. The second joint is the hotline to the dryer joint (St to Cu), which is brazed with silver solder and requires the preparation of the St tube and protection of the connection point against corrosion. A third application on the dryer is the LOKRING stopper for sealing off the charging tube.

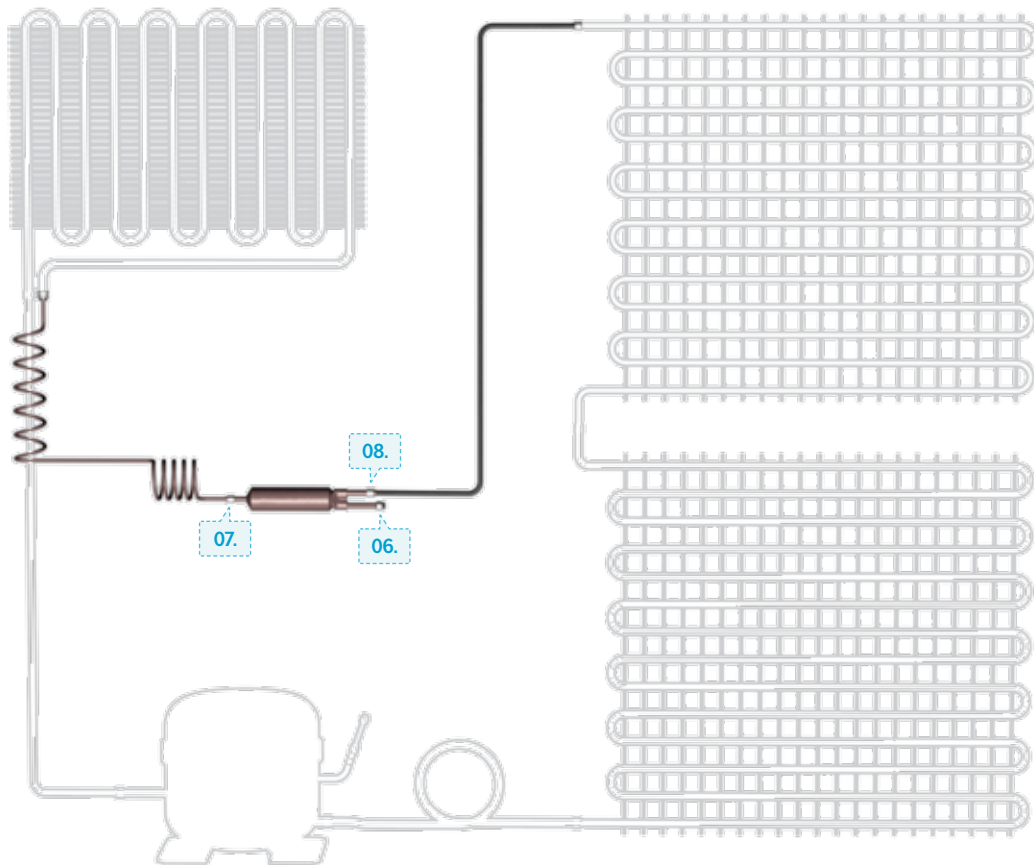

06. Dryer charging Tube



07. Dryer to Capillary Tube



08. Hotline to Dryer



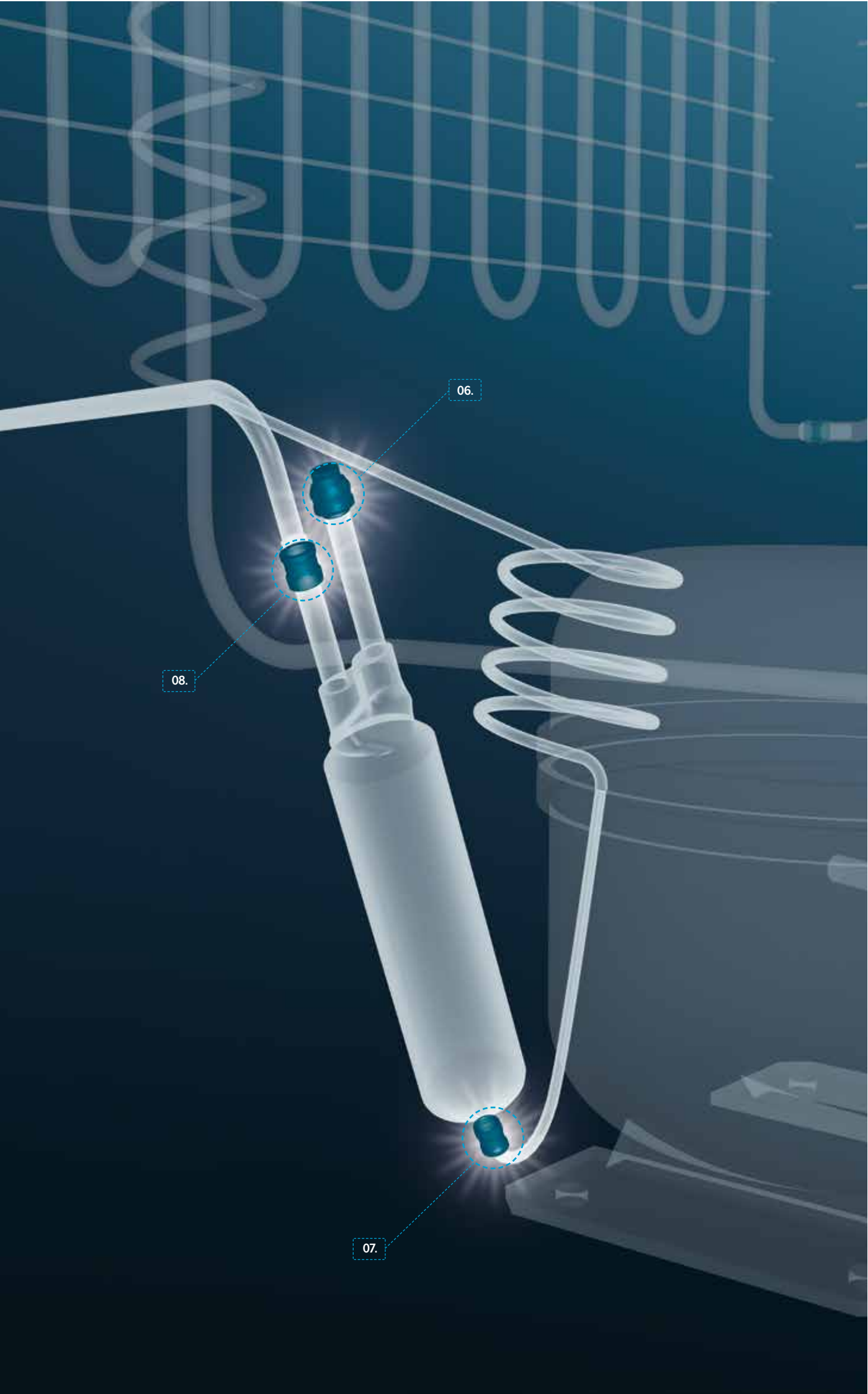

06.

08.

07.

# DRYER SECTION

THE LOKRING SOLUTIONS →

07.

**DRYER TO CAPILLARY TUBE. Cu to Cu joint with maximum quality problems from leaks or chokes.**



## PROBLEMS OF BRAZING

- ⌚ For proper brazing the joint needs to be preheated. As the capillary is very soft and its wall thickness is just 0.5 mm, the ID of the capillary may collapse and choke while preheating.
- ⌚ Preheating and brazing this joint requires the most skilled of operators.
- ⌚ Without an even preheating the capillary suffers micro porosity in the brazing flux, which results in very minute leaks occurring in the field.
- ⌚ When brazing with the high temperature required by silver solder, the capillary tube can collapse and choke.
- ⌚ Protective equipment is required against harmful brazing fumes.
- ⌚ After brazing the capillary becomes brittle and may crack while handling resulting in leakages.



## SOLDER – FREE TUBE CONNECTION

- ⌚ As LOKRING is a cold connection, you will not experience any chokes or leaks induced by preheating, uneven preheating or high temperature of brazing.
- ⌚ Modification of the dryer with extension of neck length to 12 mm is required.



## QUALITY

- ⌚ Neither leakages in the field nor in production.
- ⌚ No choking of the capillary tube by high temperature of brazing with silver solder.
- ⌚ Very clean both inside and outside.
- ⌚ No harmful brazing fumes.



## COSTS

- ⌚ No need for silver solder.
- ⌚ No high extra costs through blockages, leaks in the plant or after sales service.
- ⌚ No need for skilled operators.
- ⌚ No protective equipment required against harmful brazing fumes.

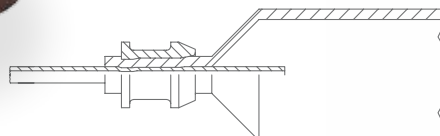

06.

**DRYER PINCH-OFF PINCHING** for sealing off the charging

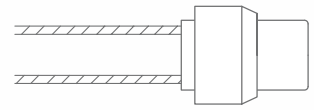

Look for more information about LOKRING in the compressor section on page 27.



## FORWARD-LOOKING

- ⌚ As the LOKRING technology moves from St to Al it is theoretically possible to seal off the capillary tube and

5. The conventional method of joining a line is ultrasonic crimping.



GRINDING STOPPER

08.

**HOTLINE TO DRYER.** St to Cu joint with high costs for silver solder and skilled operators, as well as additional operations for preparing the St tube and protecting the connection point against corrosion.



**PROBLEMS OF BRAZING**

- ⌚ For brazing, an additional operation of grinding is required to remove the zinc plating of the St tube.
- ⌚ To avoid corrosion after removing the zinc coating, the connection point has to be painted or protected by a shrinking hose.
- ⌚ For brazing this joint, typically silver solder of 30% is used – this is very expensive!
- ⌚ The joint looks very unclean after brazing and scale removal is required.
- ⌚ Protective equipment against harmful brazing fumes is necessary.



**SOLDER – FREE TUBE CONNECTION**

- ⌚ As LOKRING is a cold connection you do not face any problems induced by brazing a Cu to St joint.
- ⌚ Modification of the dryer with extension of neck length to 12 mm is required.



**MATERIAL COMBINATION**

- ⌚ Joining St to Cu with LOKRING is a reliable, fast and easy operation lasting just 10 seconds.



**COSTS**

- ⌚ No need for silver solder.
- ⌚ No need for skilled operators.



**TIME**

- ⌚ No additional operation of grinding to remove the zinc coating of the St tube.
- ⌚ No additional operation of applying paint or using shrinking hose for protection against corrosion.
- ⌚ No scale removal of the soiled joint after brazing is required.



**QUALITY**

- ⌚ No points of attack for corrosion on the St tube (no removing of zinc coating).
- ⌚ Very clean both inside and outside.
- ⌚ No hazardous fumes from burning St tube coatings.

**SOLUTIONS**

It is possible to switch the material of the dryer from Cu to Al.

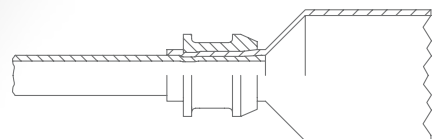



# COMPRESSOR SECTION

**COMPRESSOR SECTION.** There are 3 joints and 1 sealing of the charging tube on the compressor. All 3 joints on our (frost free) model are Cu to Cu joints. Brazing Cu to Cu joints is less critical and less expensive than joints comprising different tube materials. However, what appears to be an advantage for brazing comes at the cost of a high consumption of expensive Cu tube on the suction line and water evaporation coil. And if this is not enough, the brazing fumes are unhealthy and brazing becomes a risk in cases where hydrocarbons are used. Furthermore, the compressor is the most visible part of the cycle system and therefore brazing looks unprofessional, dirty and is often perceived as a low quality solution.

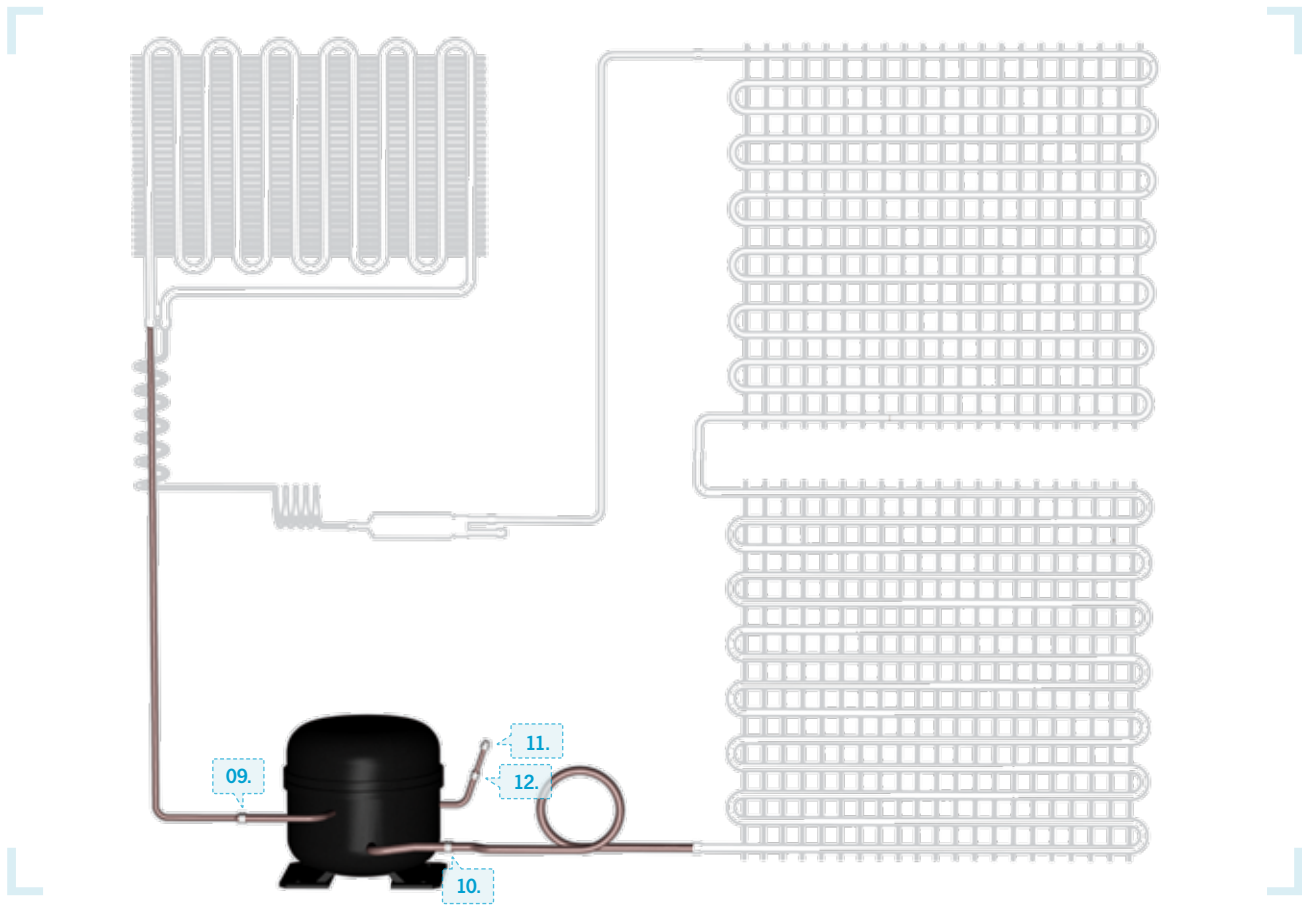

09. Suction Line to Compressor



10. Compressor to Water Evaporation Coil



12. Compressor to Charging Pinch of Pinching

11. Charging Pinch of Pinching





09.

12.

11.

10.



# COMPRESSOR SECTION

**LOKRING SINGLE RING.** Through using LOKRING, there is the possibility of achieving reasonable cost savings by switching the material of the suction tube from Cu to Al and of the water evaporation coil from Cu to St. And of course with LOKRING there are no

unhealthy fumes and no fire risks. LOKRING joints are clean both inside and outside and in the visible compressor section and therefore the refrigerator will look entirely professional and of the very highest quality.

THE LOKRING SOLUTIONS



## 09. SUCTION LINE TO COMPRESSOR. Cu to Cu joint.

### SOLDER – FREE TUBE CONNECTION

- ⌚ As LOKRING can easily join Cu to Al, you can save material costs and switch the suction tube from Cu to Al!

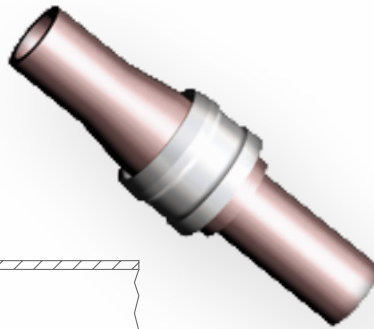
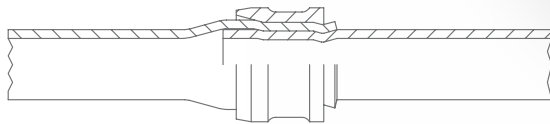

Look for more information about Al suction line at evaporator section page 15.

## 10. COMPRESSOR TO WATER EVAPORATION COIL. Cu to Cu joint.

### SOLDER – FREE TUBE CONNECTION

- ⌚ As LOKRING can easily join Cu to St, you can save material costs and switch the water evaporation coil from Cu to St!

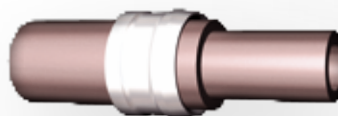
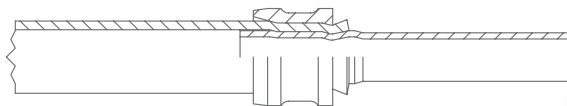

Look for more information about Al suction line at evaporator section page 15.

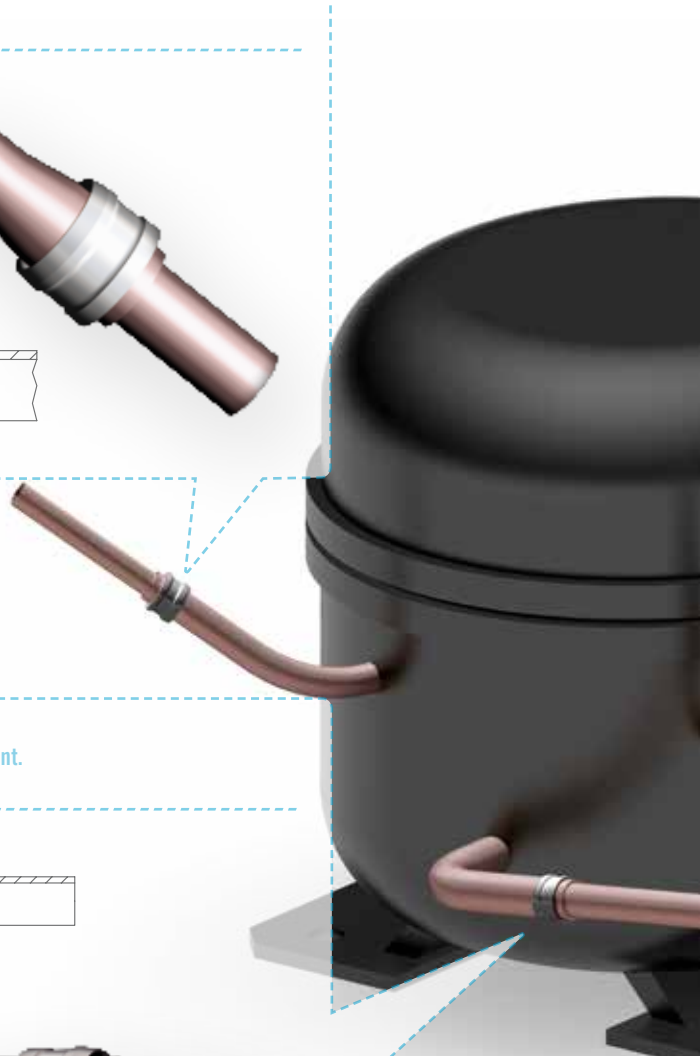

11.

**DRYER PINCH OF PINCHING.** The conventional method for sealing off the charging line is ultrasonic crimping.

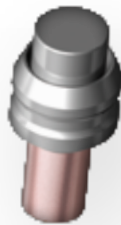
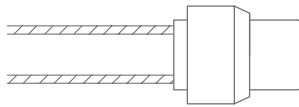

#### PROBLEMS OF ULTRASONIC CRIMPING

- ⊕ Initial investment for ultrasonic crimping is high.
- ⊕ Jaws for ultrasonic crimping are expensive and have to be changed periodically.
- ⊕ When jaws are worn-out or Cu tube quality is not perfect it causes leakages at the sealing point.
- ⊕ Crimping tool requires maintenance when used.
- ⊕ In case of hydrocarbon gas, ultrasonic welding is not without any risk.



#### COSTS

- ⊕ Initial investment for LOKRING stopper application is low.
- ⊕ No expensive spare parts required, such as crimping jaws.
- ⊕ No maintenance of the pneumatic stopper tool required.



#### QUALITY

- ⊕ No safety issue in case of hydrocarbon gas.
- ⊕ No potential for leakages.
- ⊕ Looks much more professional.

12.

**COMPRESSOR TO CHARGING PINCH OF PINCHING .** Cu to Cu joint.

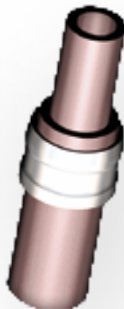
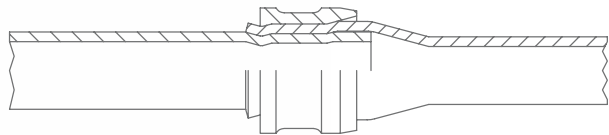

#### SOLDER – FREE TUBE CONNECTION

- ⊕ Remove brazing completely from the production line by switching to LOKRING, even though this joint is a Cu to Cu joint.







# AREAS OF NEW APPLICATIONS

# AUTOMOTIVE A/C



6 X 



6 X 



2 X 



# AUTOMOTIVE A/C



# BUS A/C

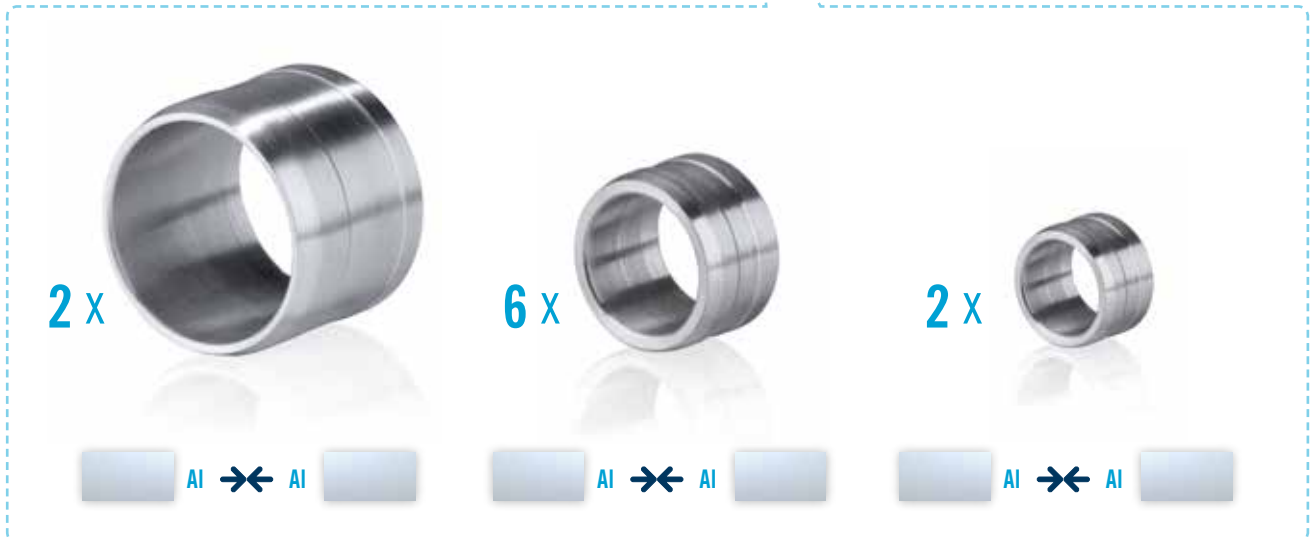



# HEAT PUMPS









# TOOLS & FUNCTION

# DESIGN AND CALCULATION

**➔ REQUESTED INFORMATION.** Due to the wide range of size and tolerance of tubes, it is unfortunately not possible to catalogue all of the available LOKRING sizes in this brochure. The individually required LOKRING SINGLE RING is designed according to the tube samples and details that are provided by the customer. To enable the design and calculation of the most suitable LOKRING the following information is required:

- ➔ tube materials, tube dimensions, dimensional tolerances and the wall thickness of tubes.
- ➔ location of the joining, which may cause stress such as vibration or torsion to the connection point.
- ➔ any physical or thermal manipulation on the tubes following the assembly of the LOKRING like bending or brazing.
- ➔ the refrigerant that is used in the system.

**➔ DESIGN, CALCULATION AND ARTICLE CODE.** Based on the information provided by the customer, VULKAN Lokring will be able to both calculate and design the most suitable LOKRING SINGLE RING. VULKAN Lokring will supply an application drawing to the customer that will confirm the tube dimensions and tolerances, as well as the suitable LOKRING SINGLE RING, by article code. This will be tested on the tube samples that are provided in their final configuration (flared, downswaged, straight) by the customer according to VULKAN Lokring’s application drawing or just straight, for aluminium tubes that the customer will flare with VULKAN Lokring’s flaring tool.

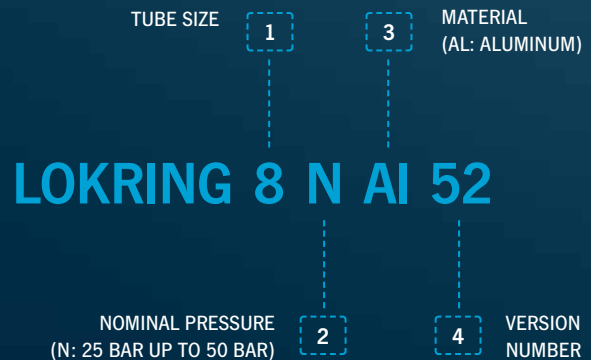
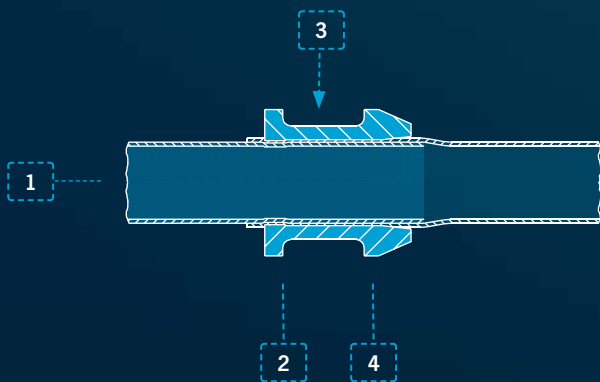

## ➔ PERMISSIBLE AREAS OF APPLICATION

- |  |  |
|--|--|
| <ul style="list-style-type: none"> <li>➔ Operating pressure:*</li> <li>➔ Test pressure:</li> <li>➔ Temperature range:</li> <li>➔ Tube wall thickness:</li> <li>➔ Tube diameter:</li> </ul> | <p>PN (nominal pressure) = 25 bar (362,5 psi) up to 50 bar (725 psi)</p> <p><math>P_p</math> (4 x PN) = 100 bar (1450 psi) up to 200 bar (2900 psi)</p> <p>-50 °C to +150 °C (-58 °F to 302 °F)</p> <p>0.5 mm to 1.5 mm</p> <p>1.6 mm to 16 mm</p> |
|--|--|

\* Depending on tube materials.

# LOKRING SINGLE RING



## LOKRING SINGLE RING



LOKRING SINGLE RING is a custom designed product for each application. Its design takes into account the tube materials that are being joined, the wall thickness and the diameters of the tubes. It is both an approved and certified system for the joining of metallic tubes.

- Permanent hermetically metal-to-metal sealing.
- Enables tubes consisting of different tube materials to be easily connected.
- High reliability.
- No special preparation of the tubes required.
- Easy and fast assembling in 10 seconds.
- Handy assembly tools.
- Considerable tolerances in dimensions are permitted.
- Clean joint both inside and outside.
- No welding, soldering or screw cutting.
- Ecologically and health wise harmless system.

# LOKPREP FUNCTION

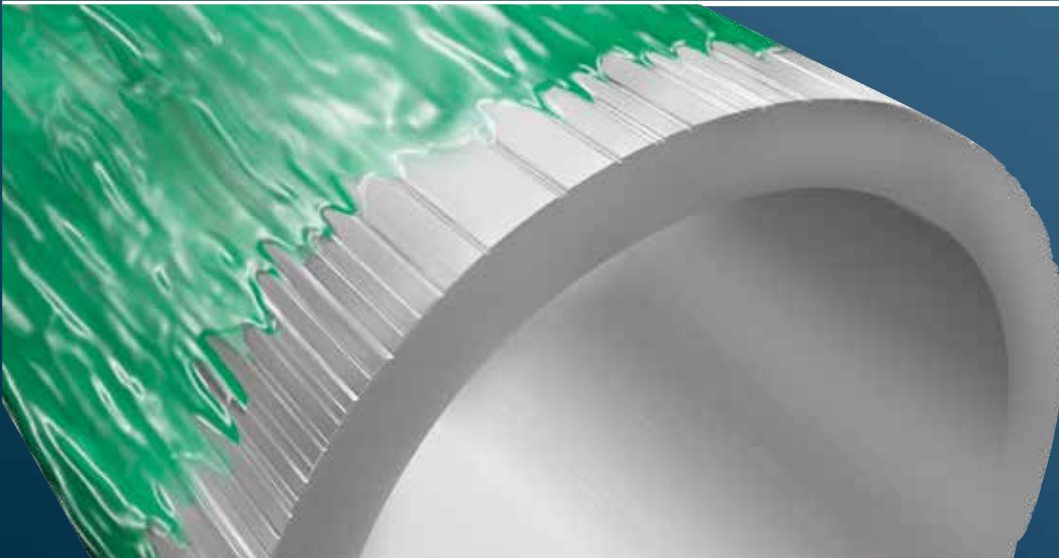

Metal tubes can have production-related longitudinal grooves or surface scratches. However, these faults can be compensated for by moistening the surfaces of the tube ends that are to be connected with LOKPREP fluid prior to assembly. Thanks to its capillary characteristic, it automatically covers the surfaces of the inserted tubes and flows into microscopic cavities and fills these out completely.

Rather than being an adhesive, LOKPREP is in fact an anaerobic sealant that hardens under oxygen exclusion and when in contact with free metal ions. At the end of the hardening process the LOKPREP sealant retains a permanently elastic structure. This means that it does not get brittle and therefore compensates for material-specific deformations. As LOKPREP does not contain solvents that have to evaporate during hardening, the finished connection is ready for pressurising and use shortly after assembly.

There are different types of LOKPREP in order to achieve an optimal effect that is primarily dependent on the materials used, the installation conditions and the ambient temperature. The choice of the LOKPREPs to be used is defined by VULKAN Lokring after the customer specifies the application.

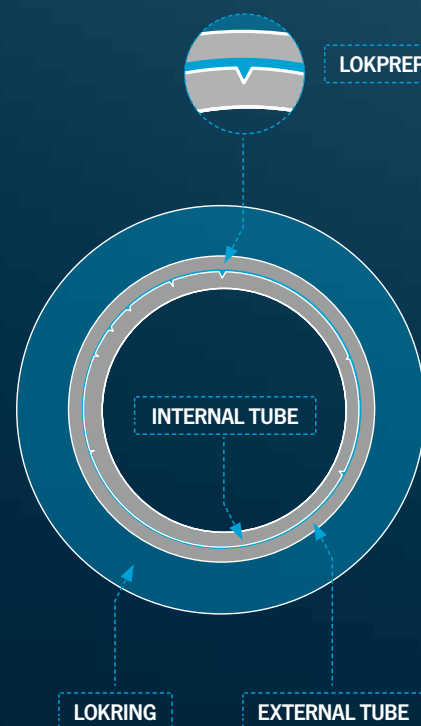



# LOKPREP



## LOKPREP



LOKPREP was developed especially for LOKRING assembly and must always be used wherever LOKRINGS are to be fitted. LOKPREP is used to provide additional safety in LOKRING connection technology and it compensates for possible unevenness in the tube surface, such as longitudinal grooves or surface porosity. Consequently, it guarantees that every LOKRING connection is hermetically sealed.

Article name	Quantity
LOKPREP 61	50 ml
LOKPREP 61/S	50 ml
LOKPREP 61 S	50 ml
LOKPREP 61 AL	50 ml

LOKPREP is developed and manufactured exclusively for VULKAN Lokring. No other product has the specific material characteristics required in order to ensure fault-free and sealed LOKRING tube connections permanently and reliably.

# OPERATIONAL INSTRUCTION

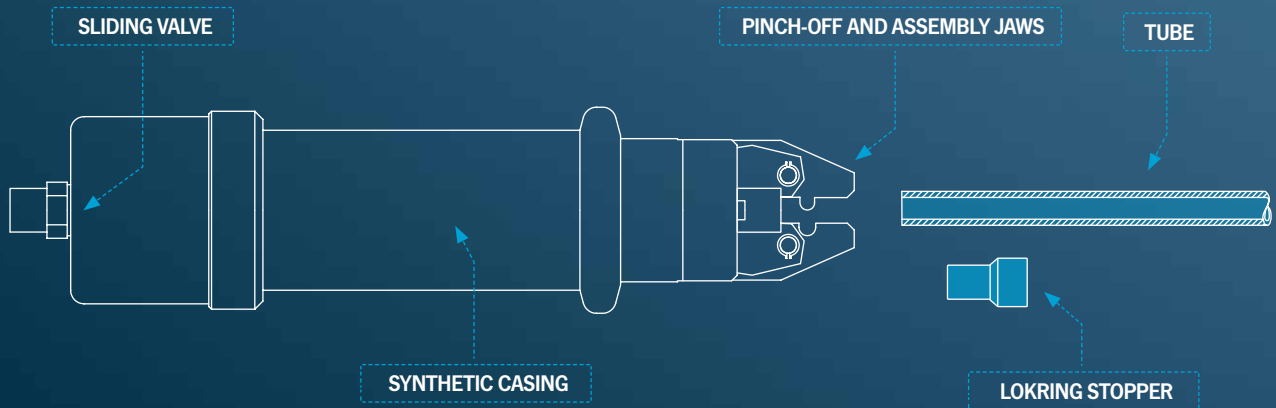

## 01 STEP

After finishing the charging, simply enter the tube into the recess of tool jaws and pinch off the tube by closing the sliding valve situated at the end of the tool. You can release the tool by opening the sliding valve.

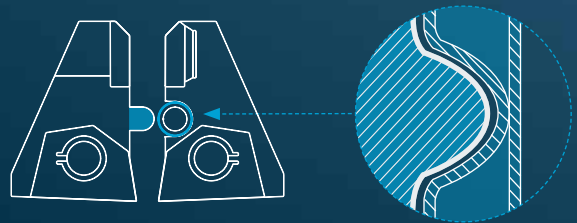

## 02 STEP

Add LOKPREP (approximately 3 mm from the tube end). Put on the LOKRING stopper with a slight motion of rotation to ensure a better distribution of the LOKPREP.

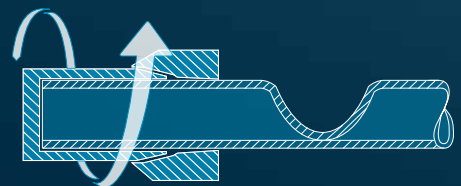

## 03 STEP

Insert the stopper which is placed on the tube in the tool jaws to ensure that the tube is fully inserted into the stopper. By operating the sliding valve, the LOKRING is pressed over the collet and seals the tube.

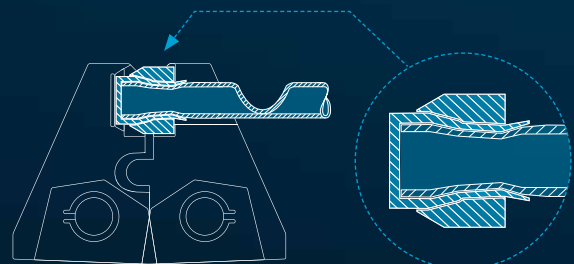

# PINCH-OFF AND ASSEMBLY TOOL



## PINCH-OFF AND ASSEMBLY TOOL



Pneumatic pinch-off and assembly tool for the leak-proof, clean and rapid sealing of the tube ends after charging the system with refrigerant agent, without welding or brazing.

Pneumatic pinch-off and assembly tool with two single acting pistons and exchangeable jaws. The actuation is set off through the sliding valve. Please note that only through using the LOKRING stopper can one guarantee the absolute closure of the sealed tube.

### Technical data

Suitable tube material:	Copper
Outer diameter of tube:	6 and 6.35 mm
Min. wall thickness of tube:	0.7 mm
Working pressure:	8-9 bar (116-130 psi)
Weight:	1.9 kg
Dimensions:	400 mm x 73 mm

# OPERATIONAL INSTRUCTION

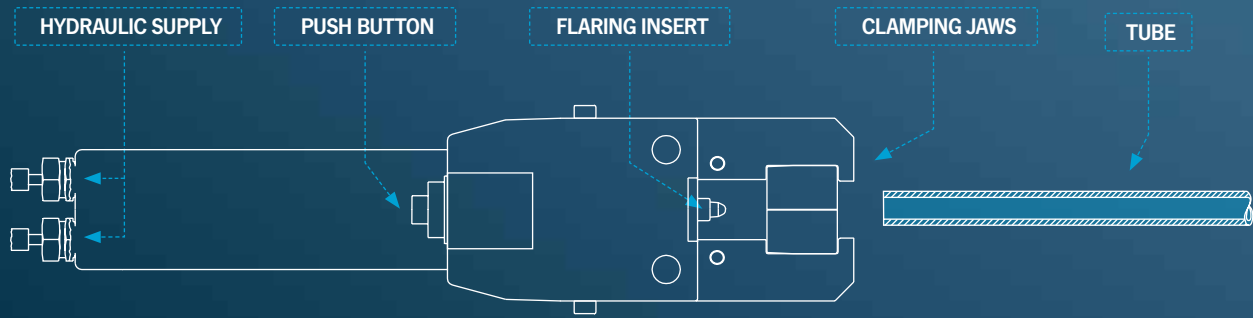

## 01 STEP

The clamping jaws have to be opened by hand and the tube end that needs to be flared must be inserted between the clamping jaws up to the flaring insert.

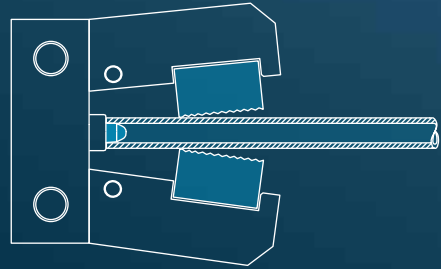

## 02 STEP

Through the actuation of the push button the tube is clamped by the clamping jaws and flared by the flaring insert.

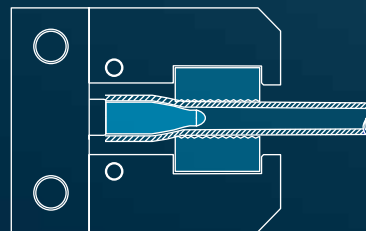

## 03 STEP

The flared tube can be removed from the tool after the flaring process has been completed.

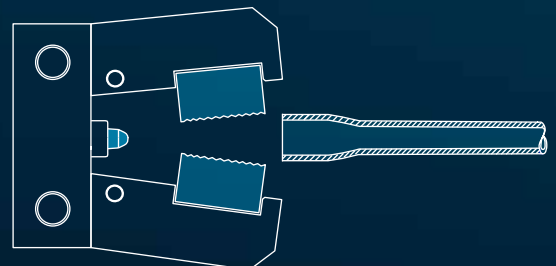



# HYDRAULIC FLARING TOOL



## HYDRAULIC FLARING TOOL



The hydraulic flaring tool is designed for the flaring of aluminium tubes for the production of LOKRING SINGLE RING tube joinings. It is connected to the LOKRING hydraulic aggregate by two 2.8 m hydraulic hoses. The forward and backward movement of the flaring insert is enabled by means of a double acting cylinder. The size of the clamping jaw and the flaring insert depends on the outside tube diameter.

### Technical data

Max. tube outside diameter:	1/2" / 12.7 mm <sup>1)</sup>
Max. tube wall thickness:	1.0 mm <sup>1)</sup>
Working pressure:	up to 320 bar
Flaring time:	approx. 1 sec.
Weight:	approx. 1.7 kg

1) Further dimensions on special request.

# OPERATIONAL INSTRUCTION

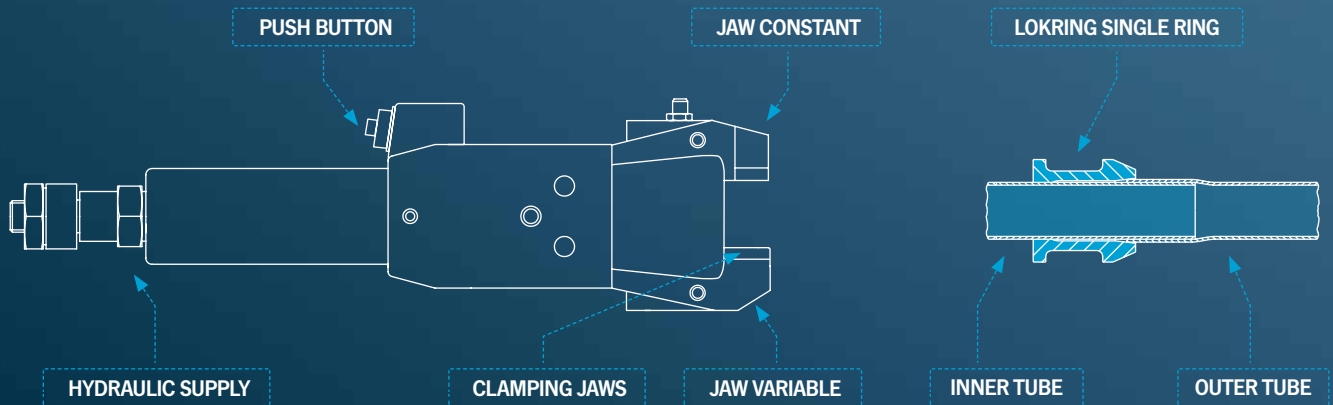

## 01 STEP

Slide the LOKRING over the inner tube so that the chamfer faces towards the tube end to be joined. Move the inner tube into the outer tube to at least “the length of the LOKRING + 3 mm” (in cases involving flared tubes, it should be up to the stop) and apply LOKPREP between the mated tubes. Place the tool in such a way that the clamping jaws are positioned on the side of the outer tube and the LOKRING can be pushed to the end of the outer tube.

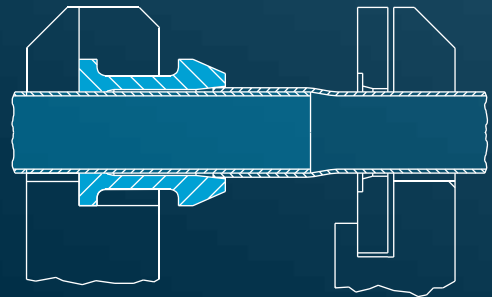

## 02 STEP

Following the actuation of the push button, the outer tube is clamped by the clamping jaws and the LOKRING is pushed over the outer tube. After the assembly, the tool switches off automatically and can be removed from the tube joining.

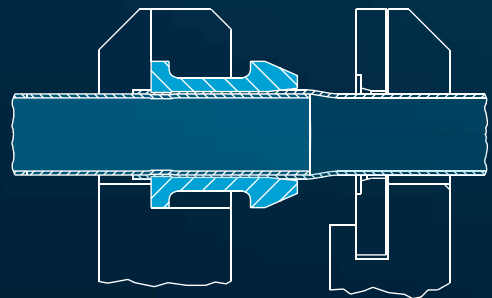

# HYDRAULIC ASSEMBLY TOOL



## HYDRAULIC ASSEMBLY TOOL



The hydraulic assembly tool enables the LOKRING connection of tubes with similar or different tube diameters. The production of the joining requires no special preparation of the tubes and can be carried out by unskilled workers.

The tool is connected to the LOKRING hydraulic aggregate by a 2.8m hydraulic hose. The sizes of the clamping and assembly jaws are dependent on the dimensions of the tubes that are to be joined.

### Technical data

Max. tube outside diameter	7/8" / 22 mm <sup>1)</sup>
Max. tube wall thickness:	1.5 mm <sup>1)</sup>
Working pressure:	up to 320 bar
Assembly time:	approx. 2 sec.
Weight:	approx. 2.0 kg

1) Further dimensions on special request.

# LIST OF PARTS

**TYPE HA  
R2.5**

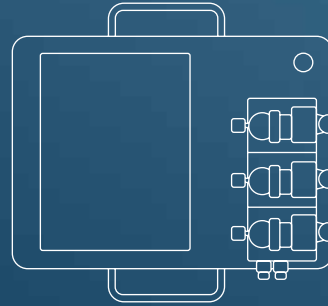
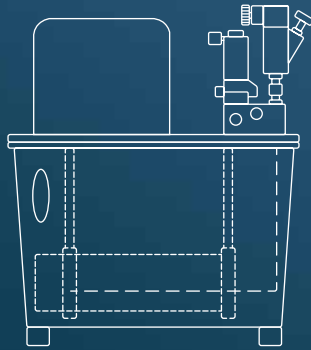

Article	Article no.	Voltage	Tools
 HA 13 R2.5	L13000889	220V, 1 Phase	1 hydraulic assembly tool 
	L13000888	220V, 3 Phase	
	L13000890	400V, 3 Phase	
 HA 23 R2.5	L13000895	220V, 1 Phase	1 hydraulic flaring tool 
	L13000894	220V, 3 Phase	
	L13000896	400V, 3 Phase	
 HA 23 R2.5	L13000892	220V, 1 Phase	2 hydraulic assembly tools  
	L13000891	220V, 3 Phase	
	L13000893	400V, 3 Phase	
 HA 33 R2.5	L13000898	220V, 1 Phase	1 hydraulic assembly tool  + 1 hydraulic flaring tool 
	L13000897	220V, 3 Phase	
	L13000899	400V, 3 Phase	
 HA 33 R2.5	L13000901	220V, 1 Phase	3 hydraulic assembly tools   
	L13000900	220V, 3 Phase	
	L13000902	400V, 3 Phase	
 HA 43 R2.5	L13000904	220V, 1 Phase	2 hydraulic flaring tools  
	L13000903	220V, 3 Phase	
	L13000905	400V, 3 Phase	
 HA 43 R2.5	L13001760	220V, 1 Phase	2 hydraulic assembly tool   + 1 hydraulic flaring tool 
	L13001759	220V, 3 Phase	
	L13001761	400V, 3 Phase	
 HA 43 R2.5	L13000907	220V, 1 Phase	4 hydraulic assembly tools    
	L13000906	220V, 3 Phase	
	L13000908	400V, 3 Phase	

HYDRAULIC FLARING TOOL



HYDRAULIC ASSEMBLY TOOL





# HYDRAULIC AGGREGATE R2.5



## HYDRAULIC AGGREGATE R2.5



The LOKRING hydraulic aggregate produces the required working pressure for the flaring and assembly tools. The aggregate is transportable and, according to its application, it is available at each workplace. The LOKRING tools are connected to the hydraulic aggregate by quick connections and hydraulic hoses. To actuate the aggregate, simply push the remote control switch that can be found on the tool. The hydraulic pressure is controlled by a switch and control gear, as well as control valves to the tools.

### Technical data

Power	1,8 kW
Number of revolutions	2850 min <sup>-1</sup>
Frequency	50 Hz
Current consumption	5 A
Protection class	IP 54
Output	2,45 l/min
Nominal pressure	350 bar
Maximal sound pressure level LP	78 dB (A)
Dimensions	400 x 300 x 400 mm
Weight	28 kg (including oil)







# LOKRING<sup>®</sup> SERVICE SOLUTIONS

# LOKRING SERVICE SOLUTIONS

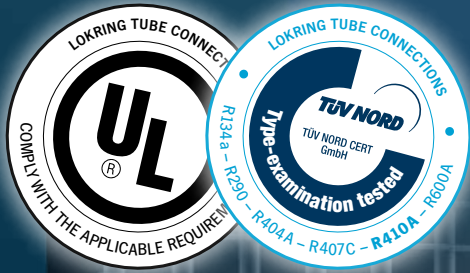

01.

04.

02.

03.





# ENDLESS POSSIBILITIES

**THE PATENTED LOKRING® TUBE CONNECTION SYSTEM** provides an innovative system of solder-free tube connections for every repair situation in refrigeration appliances. LOKRING tube connections can be made without a great deal of force being necessary, using simple hand assembly tools. LOKRING ensures an absolutely clean, permanent and purely mechanical tube connection with long-term hermetic gas-tightness. This is confirmed by the special TÜV test and approval. All this makes LOKRING tube connections one of the most economical and reliable methods of connecting refrigerant tubes.

01.



02.

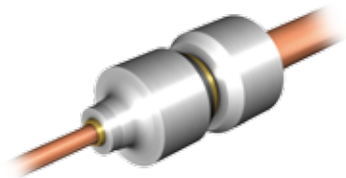

03.



04.

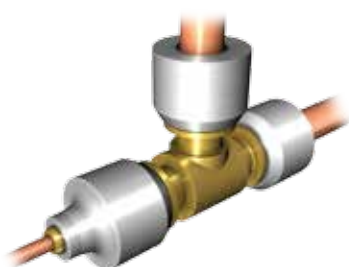

## THE BENEFITS

- Also suitable for flammable refrigerants
- Customer-friendly onsite service
- Absolutely clean, efficient and reliable
- Repair work during business hours and public access
- Repair work in situations where there is a fire hazard
- Light hand assembly tool without energy exertion
- No solder-related quality problems

## AREAS OF APPLICATION

- Household refrigeration appliances (refrigerators, freezers, wine coolers)
- Ready-to-use refrigeration equipment (refrigeration cabinets, bars, lockers, chillers)
- Refrigeration equipment for catering (sales counter refrigerators, flow-through coolers, portable cooling systems)

## ONE SYSTEM – ENDLESS POSSIBILITIES:

- Straight Connections
- Straight Reducing Connections
- Connections with schrader valve
- Capillary Connections
- Elbows
- T-connections
- Stoppers

## WITH LOKRING YOU CAN:

- Replace a compressor
- Replace a drier
- Replace a charging tube
- Repair leaky tubes

# LOKRING SERVICE SOLUTIONS

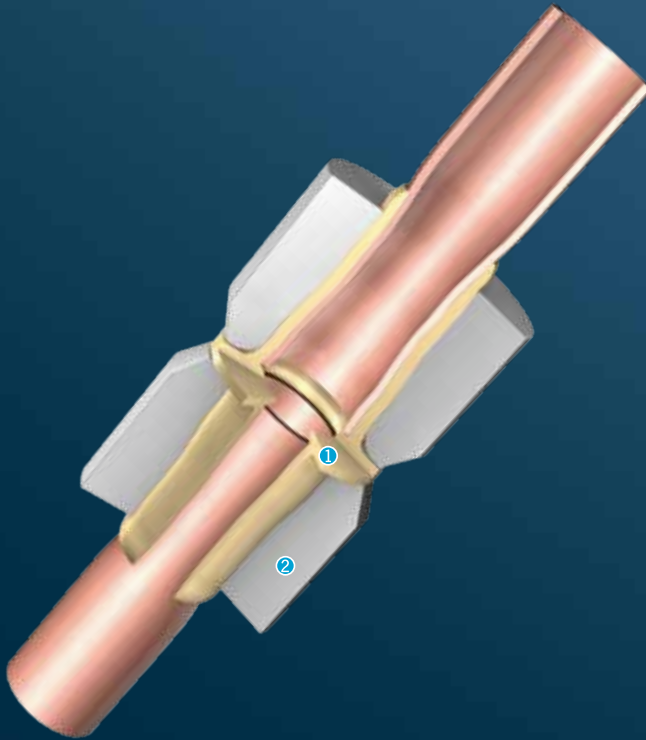

## COMPONENTS



## COMPONENTS



## MATERIAL COMBINATIONS

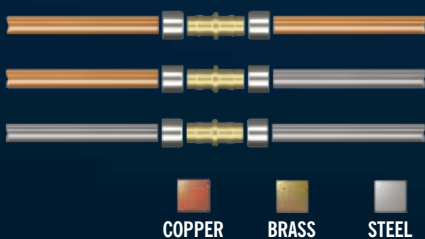

## MATERIAL COMBINATIONS

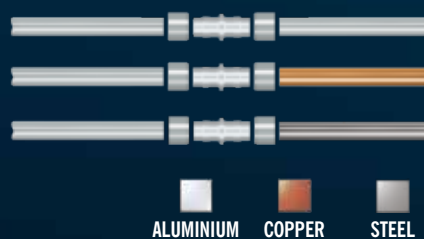

\*Solutions for higher operating pressures on request.

# BRASS / ALUMINIUM CONNECTORS

**THE TYPICAL LOKRING** union joint consists of two LOKRINGS and one tubular joint for the acceptance of the two tube ends. Thanks to the conical inner contour of the LOKRING and the special outer contour of the joint, the diameter of the connection is reduced during assembly to such an extent that the joint and the tube create a hermetically sealed metal-to-metal connection. The lifetime gas-tightness of the fitted connection is ensured by the state of permanent elastic pre-tension, which is produced by the radial forces of the LOKRINGS acting in the opposite direction to the tube-joint connection.



## TECHNICAL SPECIFICATIONS

**Reference standards:**

EN 378-2 and EN 16084

**Max. operating pressure:**

25 bar\* (360 psi\*)

**Admissible refrigerants:**

Suitable for all HCs, HFCs and mixtures.

Not suitable for NH<sub>3</sub>.

**Temperature range:**

-50°C up to 150°C (-58°F up to 302°F)

**Tube diameter range:**

1.6 to 11 mm (1/16" to 3/8")

**Minimum tube wall thickness:**

0.5 mm

**Approvals:**

TÜV (Registered No. 44 780 08 344780)

UL (File SA12004)

## TECHNICAL SPECIFICATIONS

**Reference standards:**

EN 378-2 and EN 16084

**Max. operating pressure:**

25 bar (360 psi)

**Admissible refrigerants:**

Suitable for all HCs, HFCs and mixtures.

Not suitable for NH<sub>3</sub>.

**Temperature range:**

-50°C up to 150°C (-58°F up to 302°F)

**Tube diameter range:**

2 to 9 mm (5/64" to 5/16")

**Minimum tube wall thickness:**

0.5 mm

**Approvals:**

TÜV (Registered No. 44 780 08 344780)

UL (File SA12004)

# THE BEST CONNECTION —



## → NETHERLANDS

**VULKAN Benelux**  
Van Coulsterweg 3  
2952 CB Alblasterdam  
Phone +31 78 6810780  
Mail [info@vulkan-benelux.com](mailto:info@vulkan-benelux.com)

## → GREAT BRITAIN

**VULKAN Industries Ltd**  
Archer Road  
Armytage Road Industrial Estate  
Brighouse, West Yorkshire  
Phone +44 14 84 712 273  
Mail [info@vulkan.co.uk](mailto:info@vulkan.co.uk)

## → FRANCE

**VULKAN France SA**  
12, Avenue Emile Zola, Zac de L'Agavon  
13170 Les Pennes Mirabeau  
Phone +33 4 42 02 21 06  
Mail [ppeignard@vulkan.fr](mailto:ppeignard@vulkan.fr)

## → SPAIN

**VULKAN Española S.A.**  
Avda. Montes de Oca 19, Nave 7  
28709 San Sebastián de los Reyes, Madrid  
Phone +34 91 359 09 71  
Mail [vulkan@vulkan.es](mailto:vulkan@vulkan.es)

## → ITALY

**VULKAN Italia S.r.l.**  
Via dell'Agricoltura 2  
15067 Novi Ligure (AL)  
Phone +39 0143 310 211  
Mail [info@vulkan-italia.it](mailto:info@vulkan-italia.it)

## → UNITED STATES OF AMERICA

**American VULKAN Corporation**  
2525 Dundee Road  
Winter Haven, Florida 33884  
Phone +1 863 324 2424  
Mail [vulkanusa@vulkanusa.com](mailto:vulkanusa@vulkanusa.com)

## → BRAZIL

**VULKAN do Brasil Ltda.**  
Avenida Tamboré, 1113  
CEP 06460-915 Barueri, SP  
Phone +55 11 4166 6600  
Mail [vendas.lokring@vulkan.com.br](mailto:vendas.lokring@vulkan.com.br)

# WORLDWIDE

## GERMANY

**VULKAN Lokring Rohrverbindungen GmbH & Co. KG**

Heerstraße 66, 44653 Herne

Phone +49 23 25 92 21 55

Mail [info.lok@vulkan.com](mailto:info.lok@vulkan.com)

## TURKEY

**VULKAN TURKEY Mühendislik, Denizcilik ve San. Ürünleri Tic. Ltd. Sti**

Yeşilbağlar Mahallesi, Fener Sokak No.2

Beyaz Ofis B Blok No.318

34893 Pendik – Istanbul

Tel. +90 216 680 0535 36

Mail [kagan.hasircioglu@vulkan.com](mailto:kagan.hasircioglu@vulkan.com)

## KOREA

**VULKAN Korea Corporation**

Samsung Haeundae Bldg 4F

1153-8, Jung 1 Dong, Haeundae Gu, Busan

Phone +82 51 256 2473

Mail [kim-namseol@vulkan-korea.co.kr](mailto:kim-namseol@vulkan-korea.co.kr)

## JAPAN

**Nippon VULKAN Co., Ltd.**

6-28 Nishikobari – Ina-machi

Kitaadachi-gun

F – Saitama 362-0811

Phone +81 4 8729 0202

Fax +81 4 8729 0055

Mail [info@vulkan-nippon.co.jp](mailto:info@vulkan-nippon.co.jp)

## CHINA

**WUXI VULKAN Technologies Co., Ltd.**

Shanghai Branch

Room 11B2, Building Long Life

1566, Road Yan An(W)

Shanghai, 200052 / P. R. China

Phone +86 21 5237 7001

Mail [hou.qing@vulkanchina.com](mailto:hou.qing@vulkanchina.com)

## INDIA

**VULKAN Technologies Pvt Ltd**

Gat No. 1097/1102, Urawade Road

Pirangut Industrial Area

Tal: Mulshi, Dist : PUNE – 412 115

Phone +91 20 66765527

Mail [vulkan@vsnl.net](mailto:vulkan@vsnl.net)

## SOUTH AFRICA

**VULKAN South Africa**

Suite FB002, 1st Floor

Birkdale House, River Park

Liesbeek Parkway, Settlers Way

Mowbray, Cape Town

Phone +27 21 5515194

Mail [info@vulkansa.co.za](mailto:info@vulkansa.co.za)

## SINGAPORE

**VULKAN Industries Far East PTE Ltd**

37C Benoi Road, Pioneer Lot

627796 Singapore

Phone +65 6578 9690

Mail [info@vulkan.com.sg](mailto:info@vulkan.com.sg)

## AUSTRALIA

**VULKAN Industries Far East Pte Ltd**

12 Wollong St, PO Box 790

Gosford NSW 2250

Phone +61 2 43 22 85 33

Mail [info@vulkan.com.au](mailto:info@vulkan.com.au)



# ONLINE-SERVICE

FOR FURTHER INFORMATION, PLEASE REFER  
TO OUR WEBSITE **WWW.VULKAN.COM**.



## AUTHORISED DISTRIBUTORS

[www.vulkan.com/en-us/lokring/contact/](http://www.vulkan.com/en-us/lokring/contact/)



## VIDEOS

[www.vulkan.com/en-us/lokring/videos/](http://www.vulkan.com/en-us/lokring/videos/)



## TECHNICAL DOCUMENTATION AND SUBMITTAL

[www.vulkan.com/en-us/lokring/downloads/technical-documentation-and-submittal](http://www.vulkan.com/en-us/lokring/downloads/technical-documentation-and-submittal)



## CATALOGUES & BROCHURES

[www.vulkan.com/en-us/lokring/downloads/](http://www.vulkan.com/en-us/lokring/downloads/)



## CERTIFICATES

[www.vulkan.com/en-us/lokring/downloads/certificates/](http://www.vulkan.com/en-us/lokring/downloads/certificates/)

---

# IMPRINT

---

**PUBLISHER:**

VULKAN Lokring Rohrverbindungen GmbH & Co. KG  
Heerstraße 66, 44653 Herne / Germany  
Tel.: + 49 (23 25) 922-155  
Fax: + 49 (23 25) 51222  
E-mail: [info.lok@vulkan.com](mailto:info.lok@vulkan.com)

**CONCEPT AND DESIGN:**

Hackforth Holding GmbH & Co. KG  
Marketing Service Center  
Heerstraße 66, 44653 Herne / Germany  
E-mail: [marketing@vulkan.com](mailto:marketing@vulkan.com)

**PREPRESS:**

Hackforth Holding GmbH & Co. KG  
Marketing Service Center  
Heerstraße 66, 44653 Herne / Germany  
E-mail: [marketing@vulkan.com](mailto:marketing@vulkan.com)

**VALIDITY CLAUSE**

The LOKRING® tube connection technology represents a proven method of producing hermetically sealed metal-to-metal tube connections. The LOKRING® tube connections are mainly used in the refrigeration and air conditioning industries. The use of LOKRING® tube connection technology in other fields is to be discussed with VULKAN Lokring. VULKAN Lokring as the supplier is responsible for the qualitative delivery of the tube connections and tools which are ordered from this catalogue.

The purchaser is responsible for the use of the LOKRING® tube connections and tools as directed. The assembly has to be done accordingly to the instructions and exclusively with original LOKRING® parts. The present Vehicle Air Conditioning catalogue shall replace all previous editions, any previous printings shall no longer be valid. The data contained in this catalogue refers to the valid state of affairs in time of the copy deadline. Any changes due to technical progress are reserved.

**Status:** 04/2015

All duplication, reprinting and translation rights are reserved. Further remarks for the LOKRING® assembly are available on request.

**Article no.:** L19000007

---



[www.vulkan.com/en-us/lokring/videos/](http://www.vulkan.com/en-us/lokring/videos/)